

POSÚVNE KOVANIE SI-18

obj. číslo	špecifikácia	farba
2567	sada kovania	hnedá
2567-1	sada kovania	biela
2569	profil 1,3M	hnedá
2568	profil 1,3M	biela
2569-6	profil 2,6M	hnedá
2569-5	profil 2,6M	biela

MAX: 18kg / 1 dvere

Sada kovania obsahuje:

- 2 ks spodné kolieska
- 2 ks horné vodička
- spojovací materiál

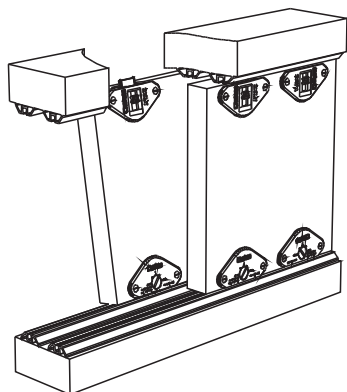

Vŕtanie  $\varnothing 35\text{mm}$

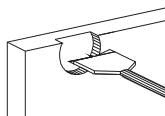

Spôsob montáže profilov

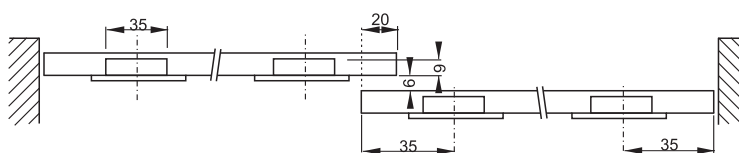
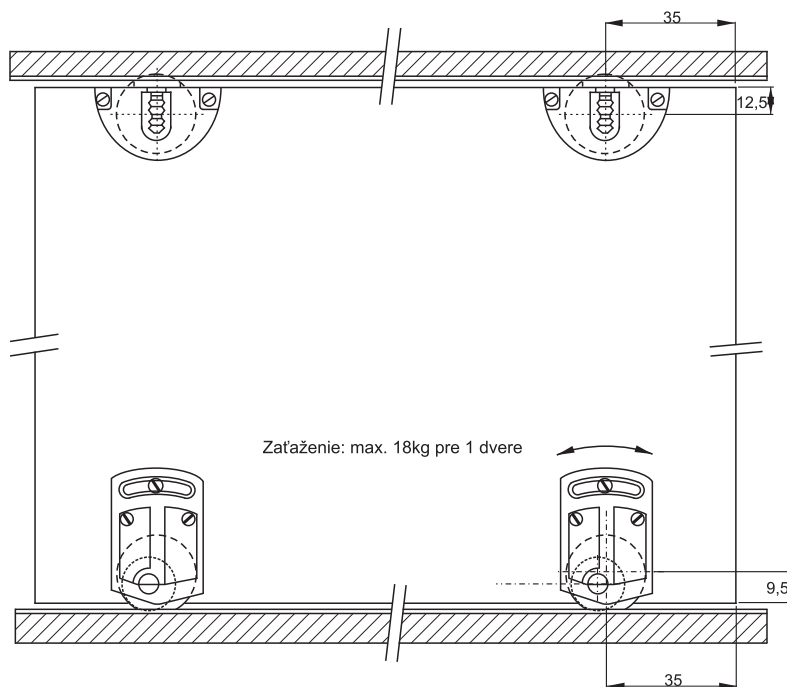
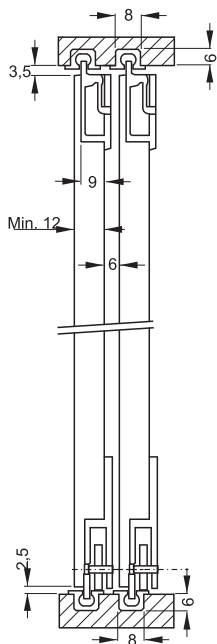
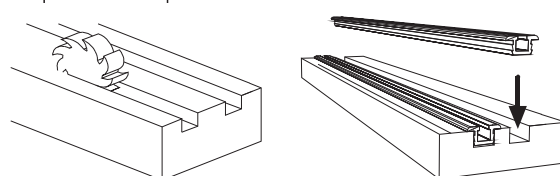
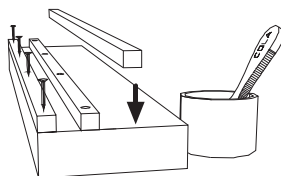

POSÚVNE KOVANIE SF-30

obj. číslo	špecifikácia	farba
5601	sada kovania	biely zinok
5602	profil 2M	hliník
5603	profil 3M	hliník

MAX: 30kg / 1 dvere

Sada kovania obsahuje:

- 2 ks horné koliesko
- 1 ks spodné vodičko
- spojovací materiál

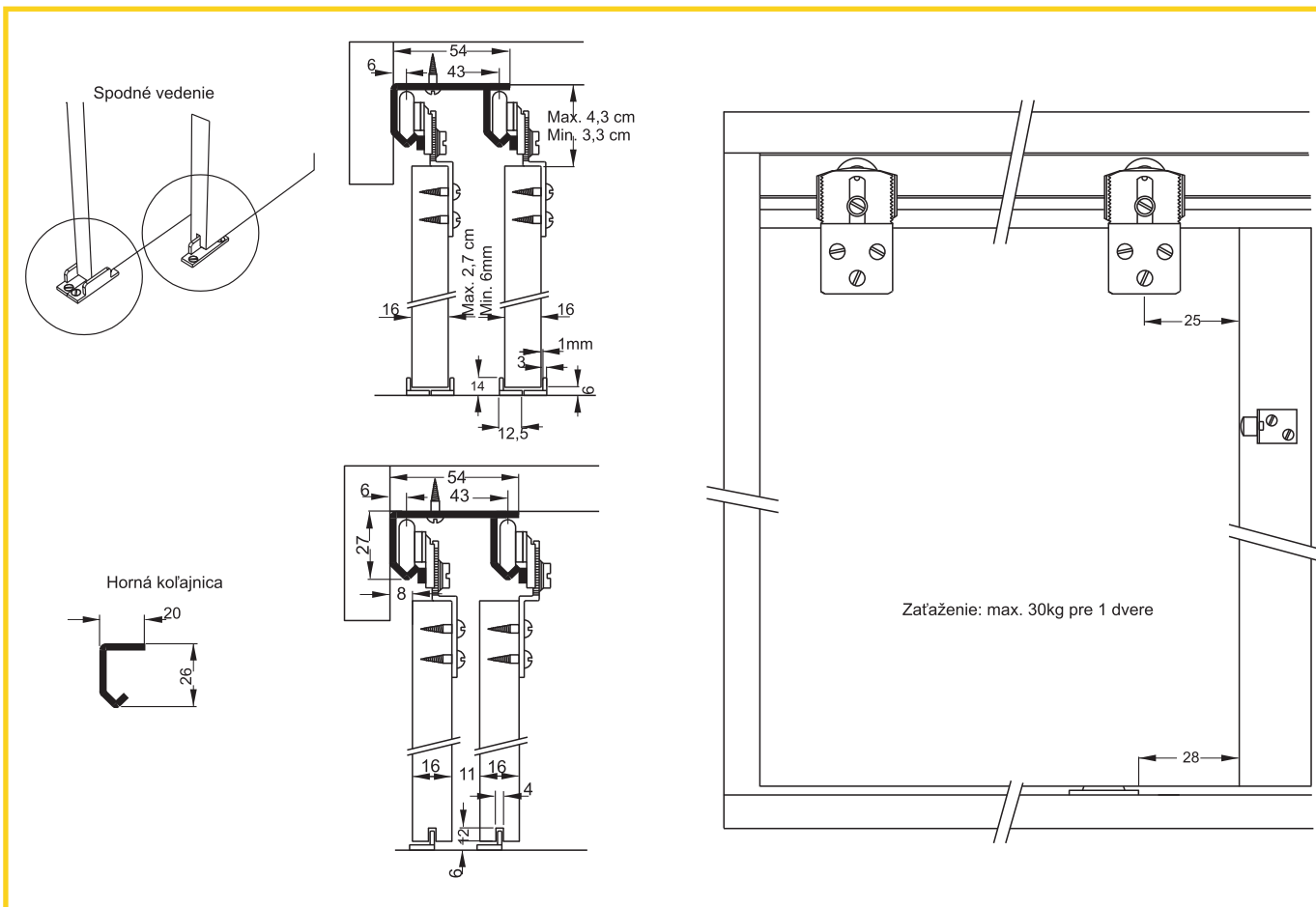
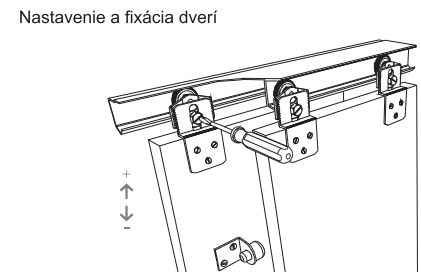
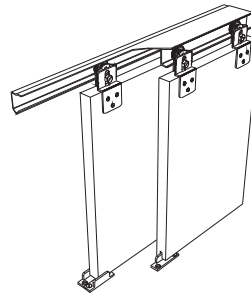
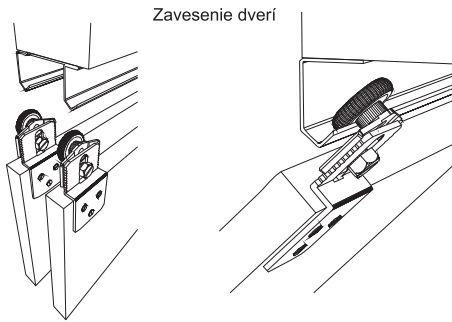
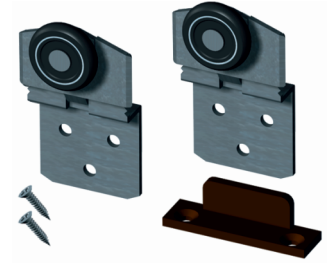

POSÚVNE KOVANIE SF-51

obj. číslo	špecifikácia	farba
5616	sada kovania	žltý zinok
5616-2	profil 2M	hliník
5616-3	profil 3M	hliník

MAX: 50kg / 1 dvere

Sada kovania obsahuje:

- 2 ks spodné koliesko
- 2 ks horné vodítko
- 1 ks doraz
- spojovací materiál

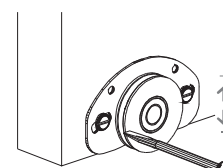
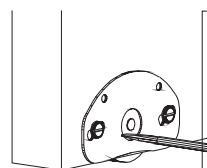
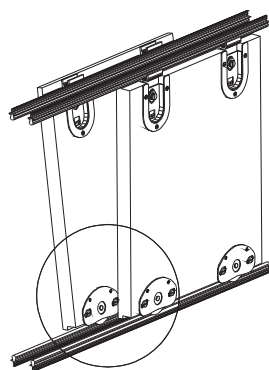
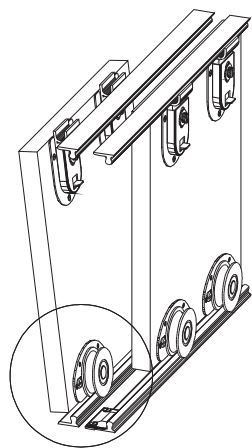

Nastavenie a fixácia dverí

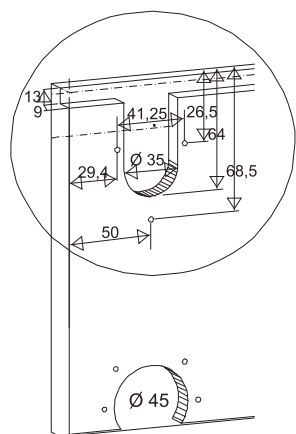
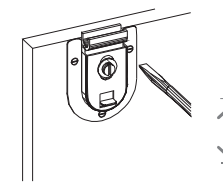
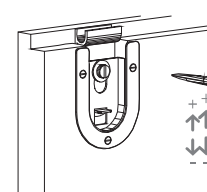

Spodná a horná koľajnica

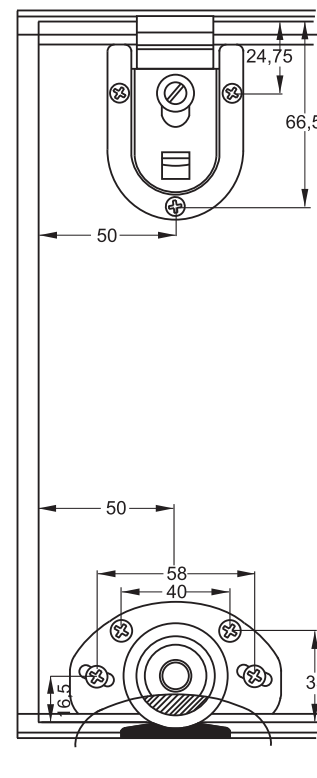
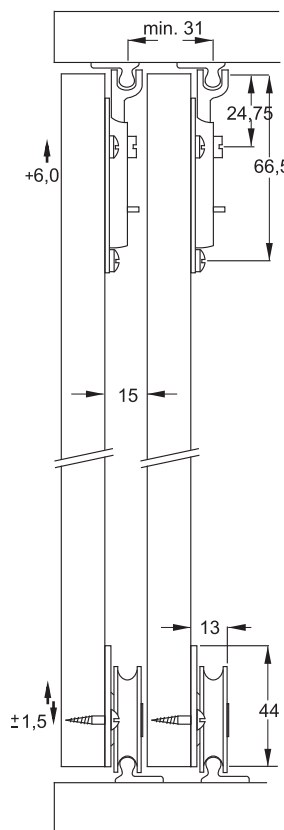
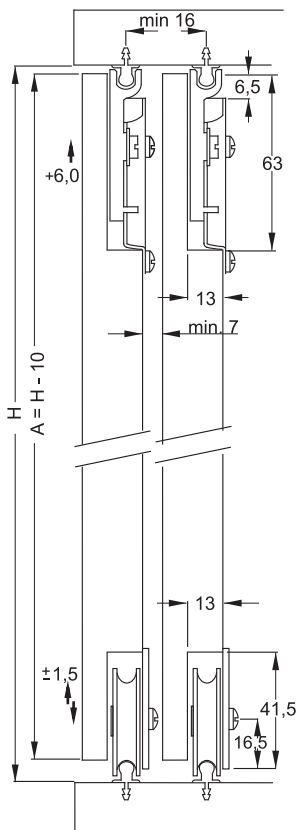

POSÚVNE KOVANIE NA SKLO X-2740

MAX: 10kg / 1 dvere

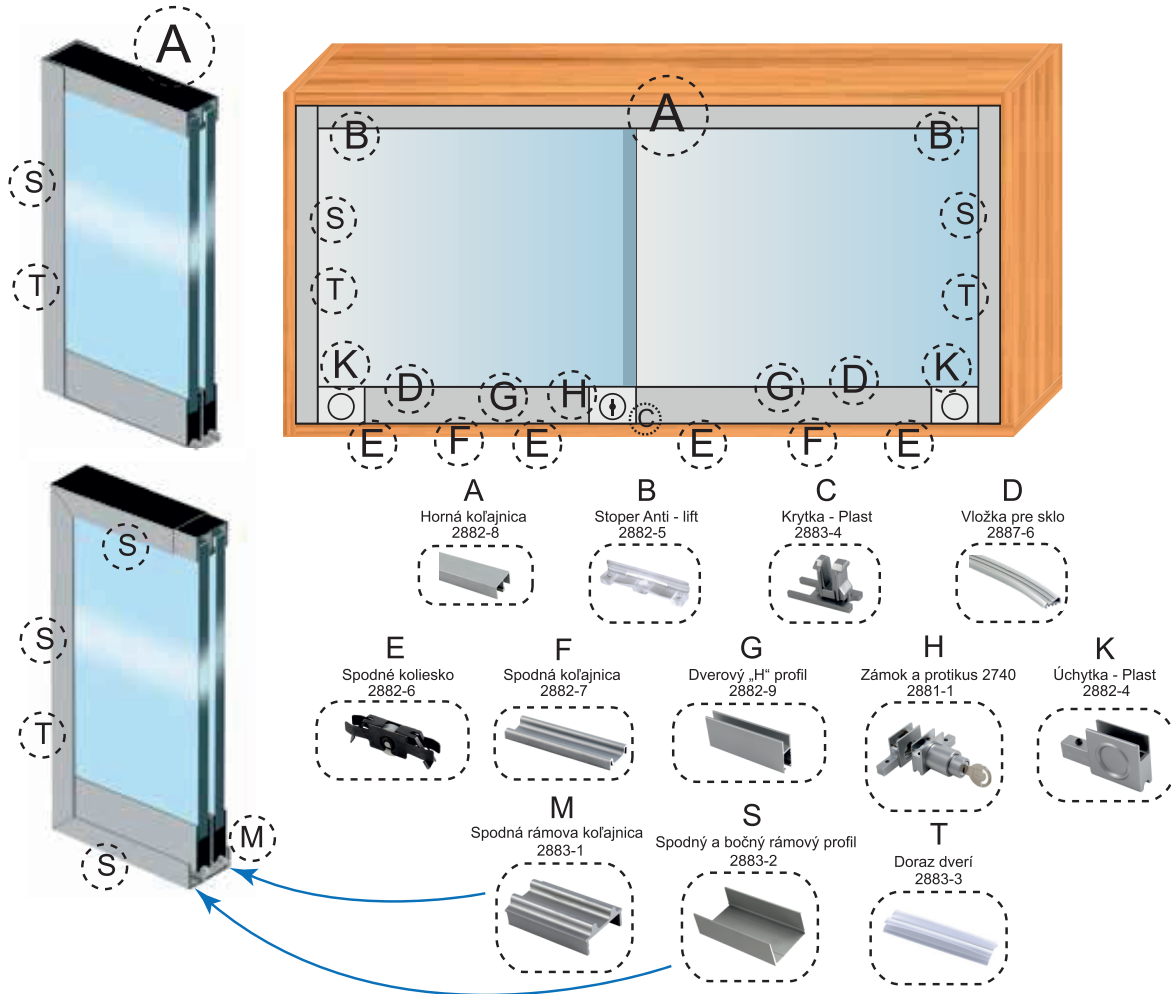

#2740 Model

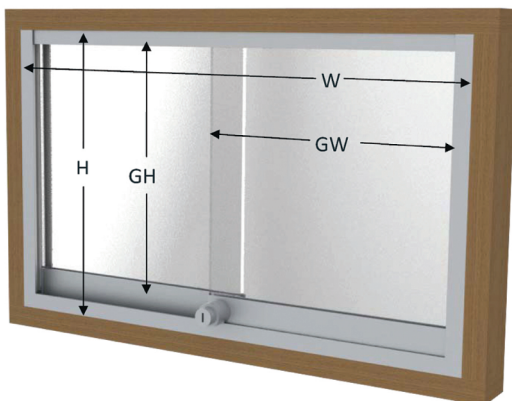

W = svetla šírka skrinky  
 GW = šírka skla  
 H = svetla výška skrinky  
 GH = výška skla

Výpočet pri použití rámového profilu:

$$GW = (W - 2,5\text{mm}) + 30\text{mm} \times 0,5$$

Rámový profil

Prekrytie dverí

Pri použití krytky odpočítať 10mm pre každé krídlo.

$$GH = H - 40\text{ mm}$$

Profil + medzera

Výpočet bez použitia rámového profilu:

$$GW = (W + 30\text{ mm}) \times 0,5$$

Prekrytie dverí

Pri použití krytky odpočítať 10mm pre každé krídlo.

$$GH = H - 25\text{ mm}$$

Profil + medzera

## POSÚVNE KOVANIE NA SKLO X-2740

## ZÁMOK 2740 S PROTIKUSOM

obj. číslo	špecifikácia
<b>2881-1</b>	400 kombinácií
<b>2881-2</b>	rovnaký kľúč
<b>2881-3</b>	MI systém



Úprava: matný chróm



## Zámok 2740

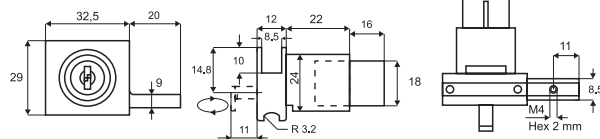

## Protikus k zámku 2740

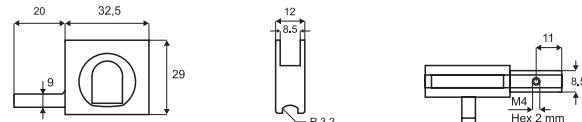

## ÚCHYTKA

obj. číslo
<b>2882-4</b>

Materiál: plast  
Úprava: matný chróm

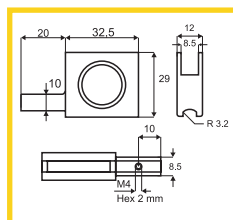

## SPODNÉ KOLIESKO

obj. číslo
<b>2882-6</b>

Nosnosť: 5 kg / 1 ks  
Úprava: zinok

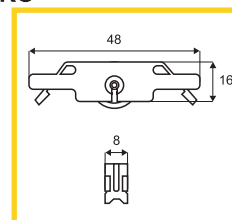

## KRYTKA PROFILU „H“

obj. číslo
<b>2883-4</b>

Materiál: plast  
Úprava: matný chróm

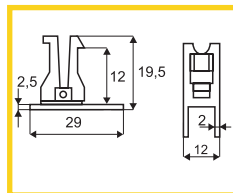

## NÁSTROJ PRE MONTÁŽ KOLIESKA

obj. číslo
<b>2883-9</b>

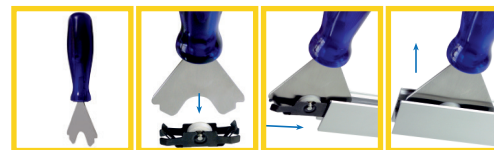

## SPODNA KOLAJNICA

obj. číslo
<b>2882-7</b>

Dĺžka: 2M  
Materiál: hliník

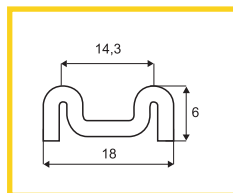

## SPODNA RÁMOVÁ KOLAJNICA

obj. číslo
<b>2883-1</b>

Dĺžka: 2M  
Materiál: hliník

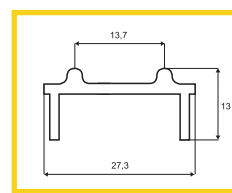

## HORNÁ KOLAJNICA

obj. číslo
<b>2882-8</b>

Dĺžka: 2M  
Materiál: hliník

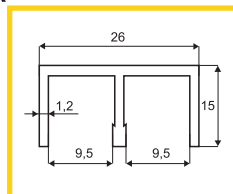

## SPODNÝ RÁMOVÝ PROFIL

obj. číslo
<b>2883-2</b>

Dĺžka: 2M  
Materiál: hliník

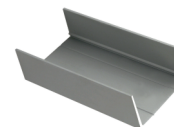
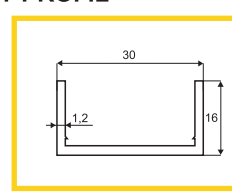

## DVEROVÝ „H“ PROFIL

obj. číslo
<b>2882-9</b>

Dĺžka: 2M  
Hrúbka skla: 5-6mm  
Materiál: hliník

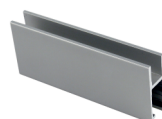
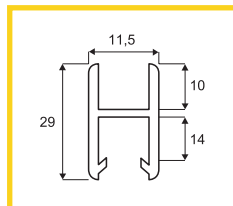

## DORAZ DVERÍ - PROFIL PVC

obj. číslo
<b>2883-3</b>

Dĺžka: 2M  
Materiál: PVC

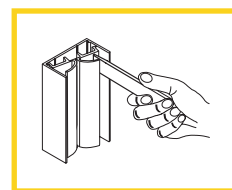

## VLOŽKA PRE SKLO PVC

obj. číslo
<b>2887-6</b>

Dĺžka: 100M  
Materiál: PVC šedá

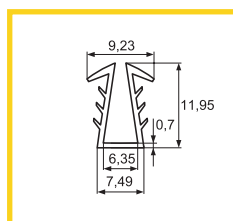

## STOPER ANTI-LIFT

obj. číslo
<b>2882-5</b>

Materiál: PVC transparentný

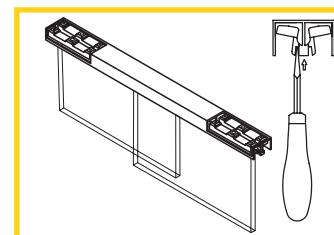

## POSÚVNE KOVANIE NA SKLO X-8600

MAX: 6kg / 1 dvere

### ZÁMOK 8600

obj. číslo	špecifikácia
<b>2887-0</b>	400 kombinácií
<b>2887</b>	rovnaký kľúč

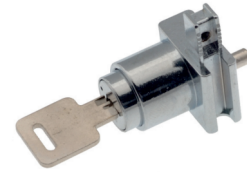
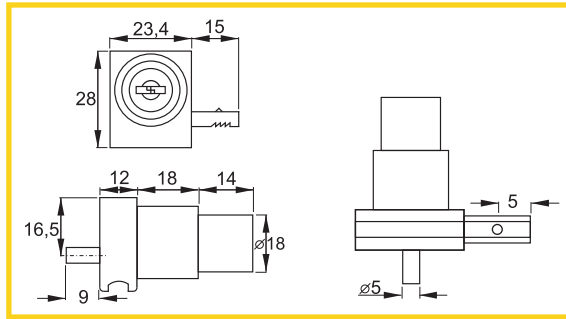

### KOLAJNICA SPODNÁ

obj. číslo	
<b>2887-1</b>	F

Materiál: hliník elox

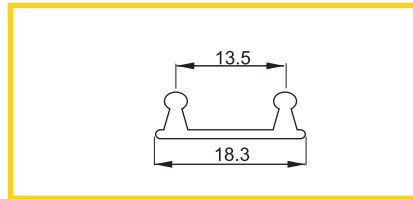

### KOLAJNICA HORNÁ

obj. číslo	
<b>2887-2</b>	A

Materiál: hliník elox

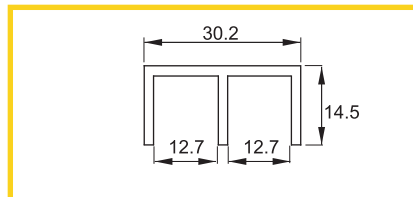

### PROFIL DVEROVÝ „H“

obj. číslo	
<b>2887-3</b>	G

Materiál: hliník elox

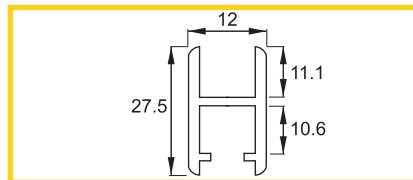

### KOLIESKO SPODNÉ

obj. číslo	
<b>2887-4</b>	E

Úprava: nikel

Nosnosť: 3 kg / 1 koliesko

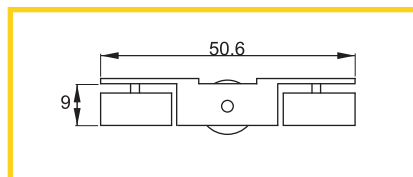

### HORNÉ VEDENIE

obj. číslo	
<b>2887-7</b>	B

Materiál: plast transparentný



### KRYTKA „H“ PROFILU

obj. číslo	
<b>2887-5</b>	C

Úprava: nikel



### VLOŽKA PRE SKLO

obj. číslo	
<b>2887-6</b>	D

Materiál: guma šedá

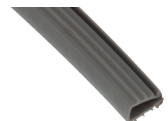

### VÝPOČET ROZMERU DVERÍ

W = svetlá šírka skrinky

H = svetlá výška skrinky

L = šírka skla

$L = (W + 30\text{mm}) : 2 - 5,5\text{mm}$

L<sub>2</sub> = dĺžka profilu H

$L_2 = L + 1,5\text{mm}$

H<sub>G</sub> = výška skla

$H_G = H - 27\text{mm}$

## POSÚVNE KOVANIE SF40, SF75

MAX: 75kg / 1 dvere

obj. číslo	špecifikácia
<b>5607</b>	SF 40 sada kovania
<b>5609</b>	SF 75 sada kovania
<b>5610</b>	profil 2M oceľ
<b>5610-1</b>	profil 3M oceľ

## Sada kovania obsahuje:

- 2 ks horné koliesko s platňou
- 2 ks doraz do koľajnice
- 1 ks vodiaci element
- 1 ks plochý kľúč
- 1 ks gumený doraz
- spojovací materiál

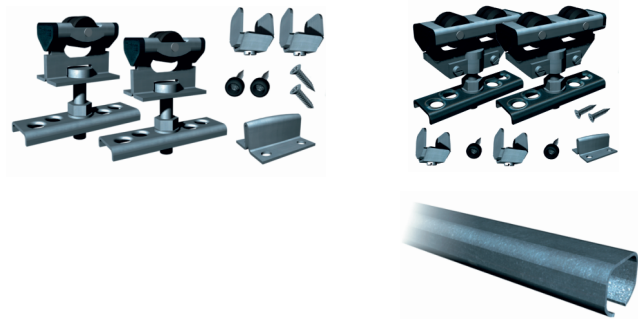

Upevnenie koľajnice

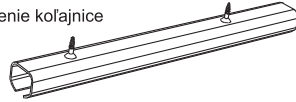

Montáž platničky

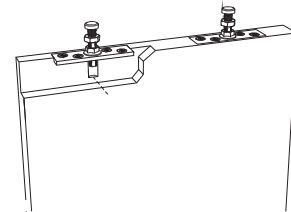

**CENA ZA SADU 2M  
OD 6,00 EUR**

Upevnenie dorazu

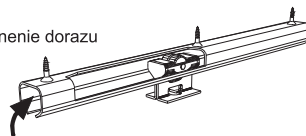

Nastavenie a fixácia dverí

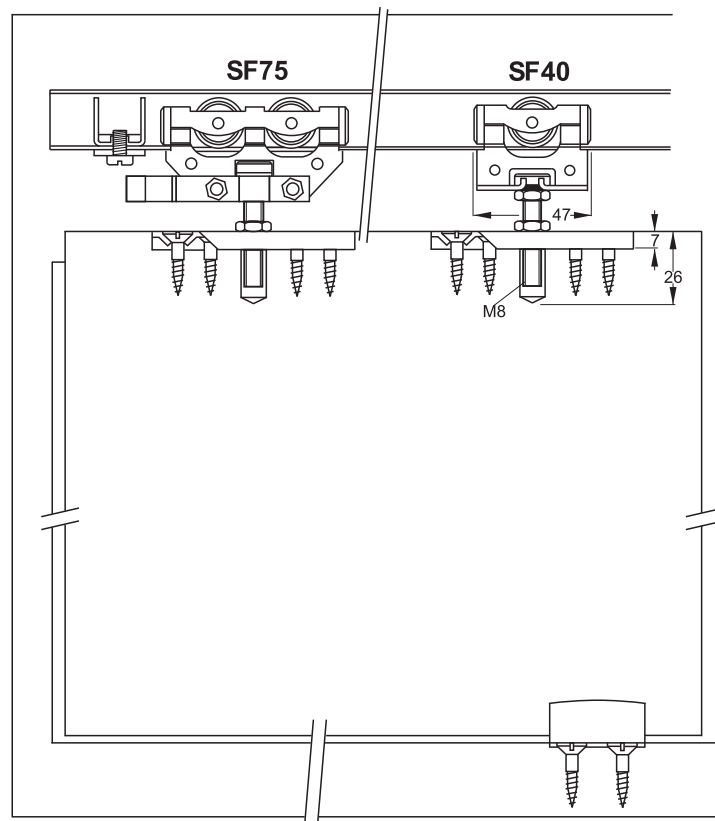
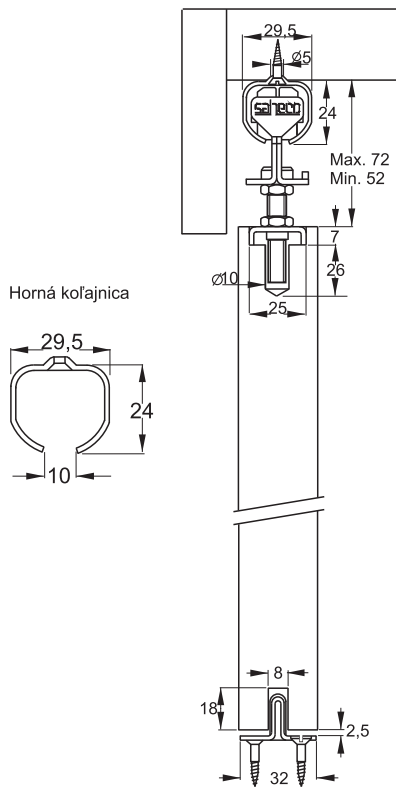
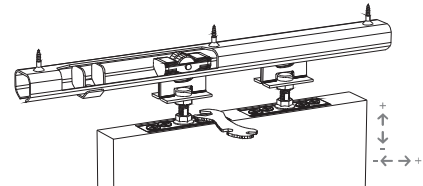

## POSÚVNE KOVANIE EKO 0400

MAX: 80kg / 1 dvere

obj. číslo	špecifikácia
1849	sada kovania + 1,8M profil
1850	sada kovania + 2,0M profil
1852	sada kovania + 3,0M profil
1840	sada kovania
1860	upínací element
1861	spodný vodiací element

### Sada kovania obsahuje:

- 2 ks horné koliesko
- 2 ks upínacia platnička
- 2 ks upínacia skrutka
- 2 ks doraz
- 1 ks spodný vodiací element

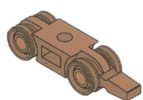

Horné koliesko

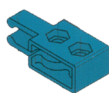

Doraz



Upínacia platnička



Spodný vodiací element



Upínacia skrutka

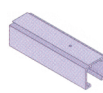

Kofajnica Al do 80kg



Upínací element

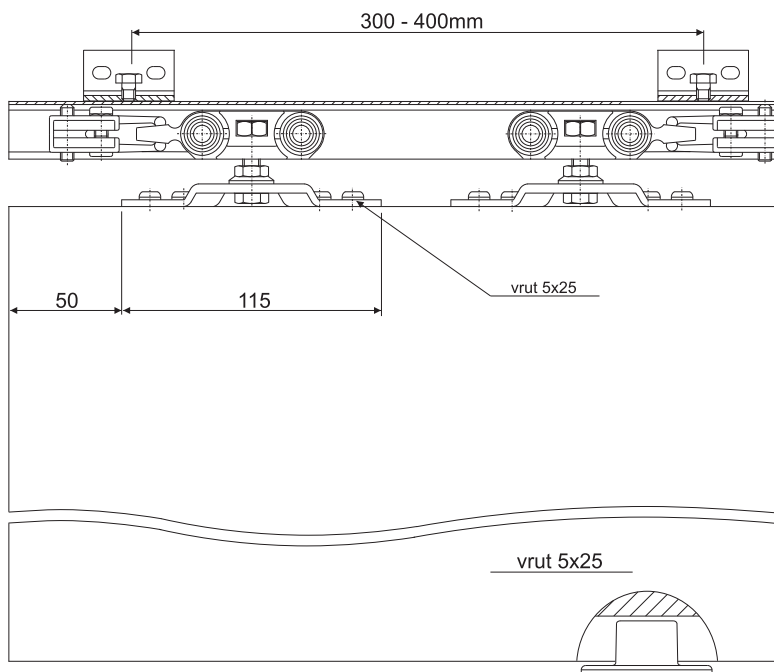
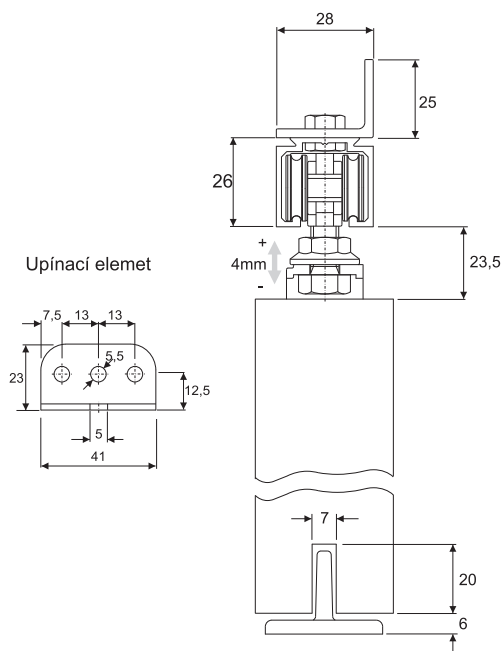
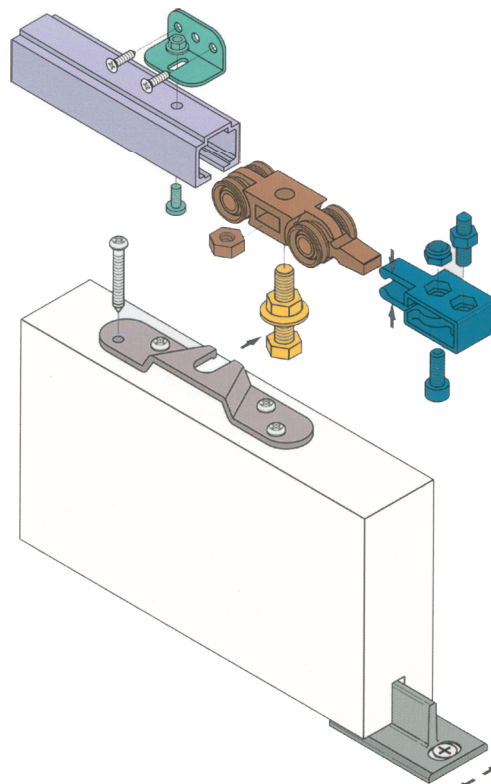



## POSÚVNE KOVANIE S-60 S TLMENIM

Max. 60kg / 1 dvere

obj. číslo	špecifikácia
<b>1855</b>	Sada kovania + profil 2,00 M

### Sada kovania obsahuje:

- 1 ks koľajnica 2 M
- 1 ABS piest s kolieskom
- 2 ks aktivátor piestu
- 1 ks horné vodiace koliesko
- 1 ks spodné vedenie
- 2 ks montážna platnička
- 1 sada montážne skrutky

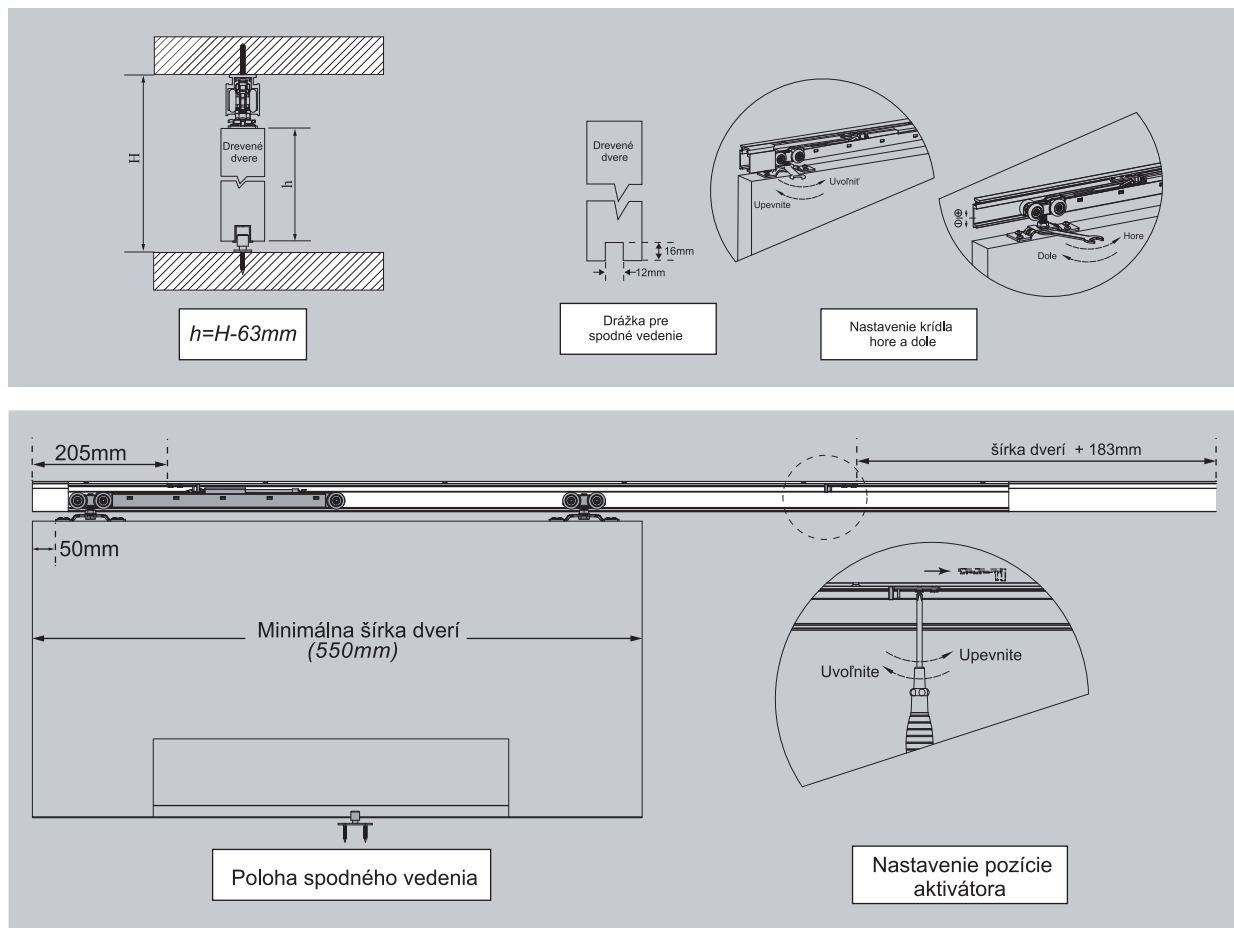

### POSÚVNE KOVANIE SI-100

MAX: 100kg / 1 dvere

obj. číslo	špecifikácia
<b>1870</b>	sada kovania + 2,0M profil
<b>1871</b>	sada kovania + 3,0M profil
<b>1872</b>	sada kovania

Sada kovania obsahuje:

- 2 ks horné kolieska
- 2 ks upínacia platnička
- 2 ks upínacia skrutka
- 2 ks doraz
- 1 ks spodný vodiaci element

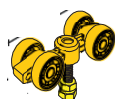
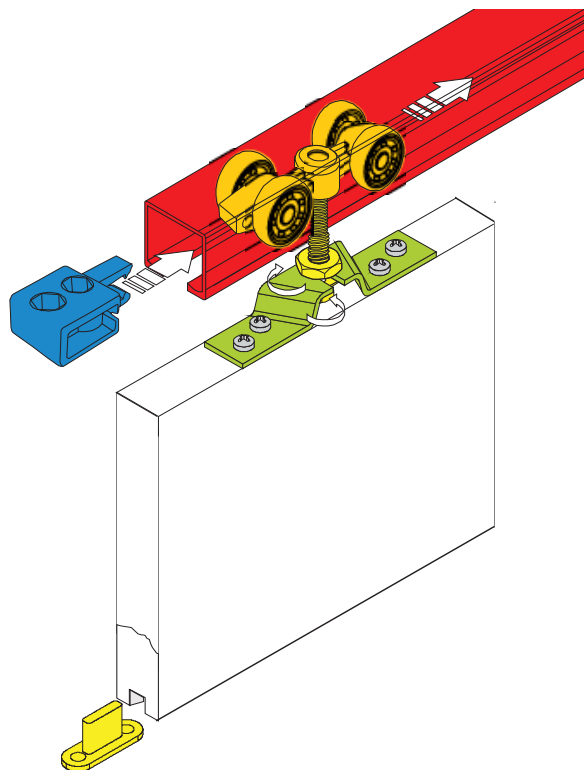

Horné koliesko

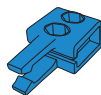

Doraz



Upínacia platnička



Spodný vodiaci element

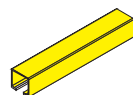

Koľajnica Al do 100kg

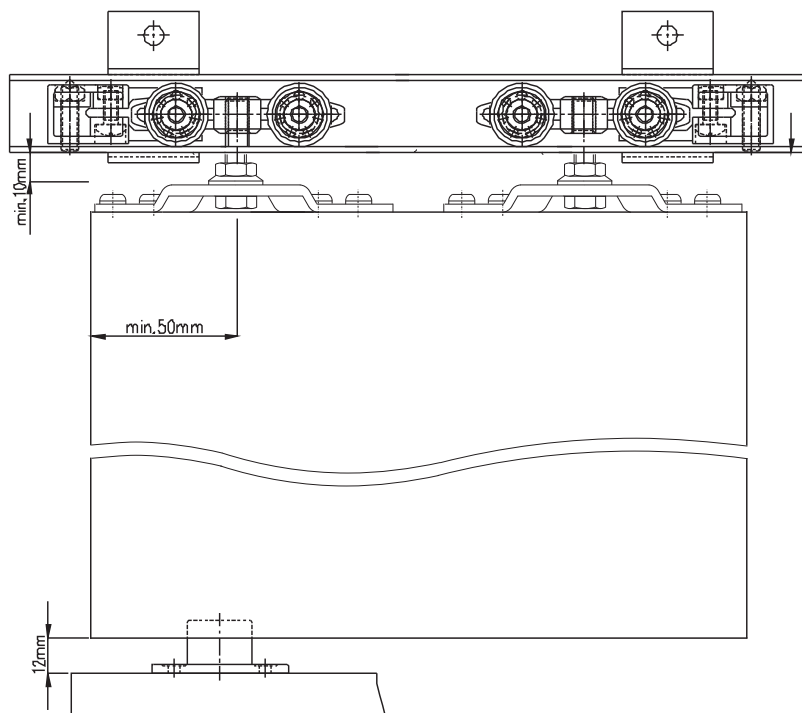
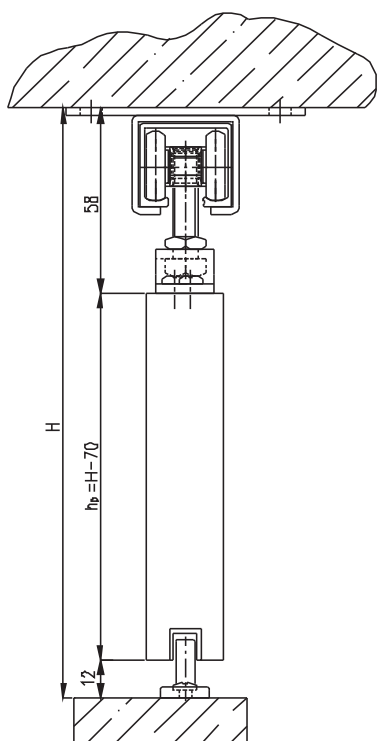



## KOVANIE PRE INTERIÉROVÉ LÁMACIE DVERE - 0260/1

MAX: 50kg / 1 dvere

obj. číslo	špecifikácia
<b>1823</b>	sada kovania P/L

**Sada kovania obsahuje:**

- 2 ks záves horný a spodný
- 1 ks otvárací mechanizmus spodná časť
- 1 ks otvárací mechanizmus horná časť
- 1 ks vrchná krytka
- 1 ks doraz
- 1 ks koľajnica hliník 1m



Doraz



Vrchná krytka



Spodný a horný záves

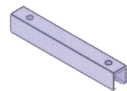

Horný Al profil 1M



Otvárací mechanizmus



Otvárací mechanizmus

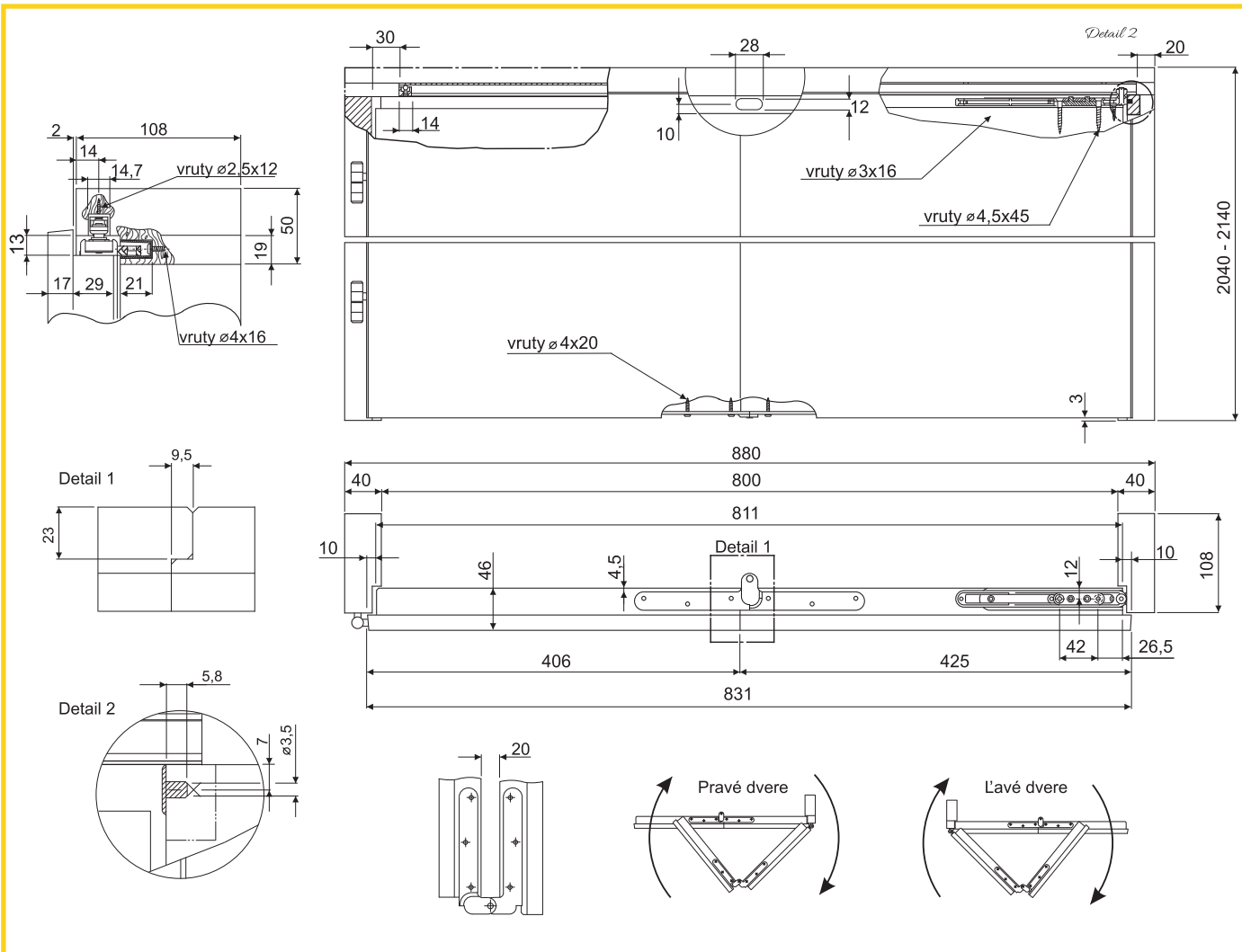
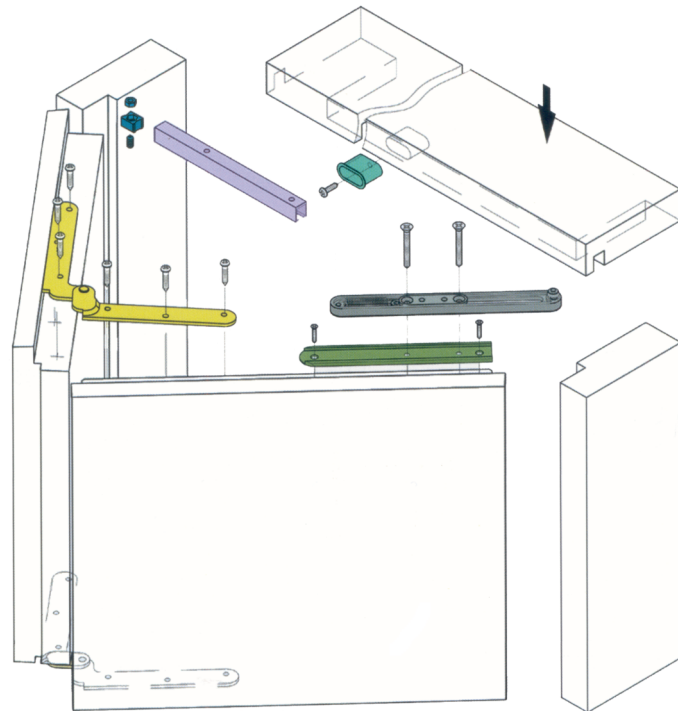



## KOVANIE PRE INTERIÉROVÉ DVERE S TÍMENÍM - 0500

MAX: 80kg / 1 dvere

obj. číslo	špecifikácia
<b>18240</b>	sada kovania 50kg
<b>18241</b>	sada kovania 80kg
<b>1883</b>	koľajnica 2M
<b>2a13</b>	koľajnica 3M
<b>1839</b>	upínací element

Sada kovania obsahuje:

- 1 ks horné koliesko
- 2 ks upínacia platnička
- 1 ABS piest s kolieskom
- 1 ks aktivátor piestu
- 1 ks mechanický doraz
- 1 ks spodné vedenie



Horné koliesko do 80kg

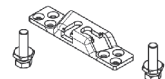

Upínacia platnička

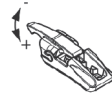

Doraz



Koľajnica Al do 80kg



Spodný vodiaci element



Aktivátor piestu



ABS piest

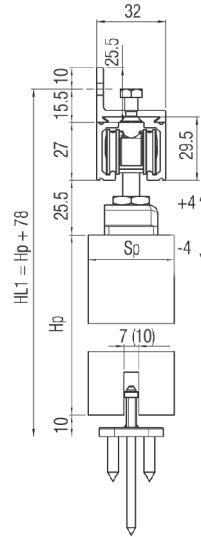
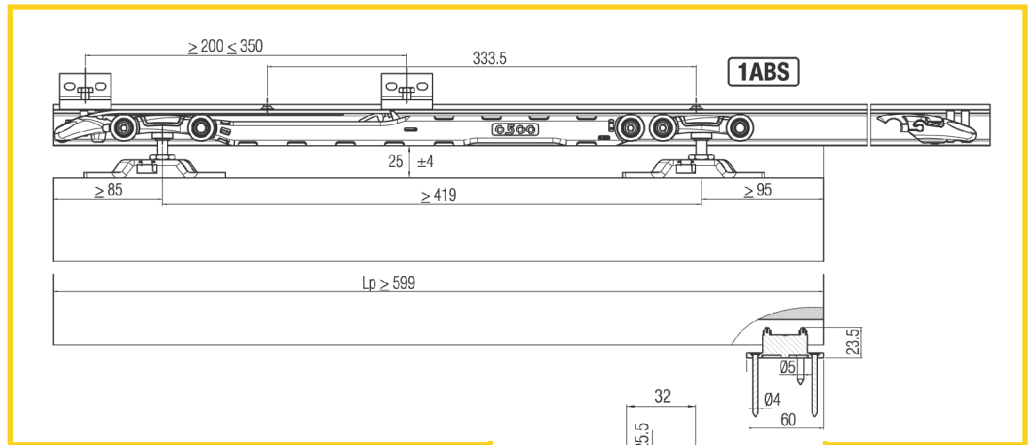

## KOVANIE PRE SKLENENÉ DVERE 1760

obj. číslo	špecifikácia
<b>1885</b>	sada kovania
<b>1886</b>	sada kovania s tímením
<b>1883</b>	koľajnica 2M
<b>a133</b>	koľajnica 3M
<b>1839</b>	upínací element

### 1885 - kovanie na sklenené dvere - mechanický doraz

Max. váha dverí - 80 kg

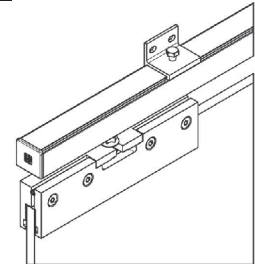
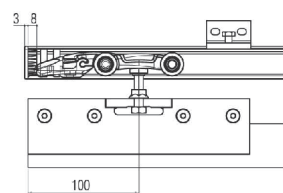
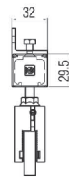

### 1886 - kovanie na sklenené dvere s tímením

Max. váha dverí - 80 kg

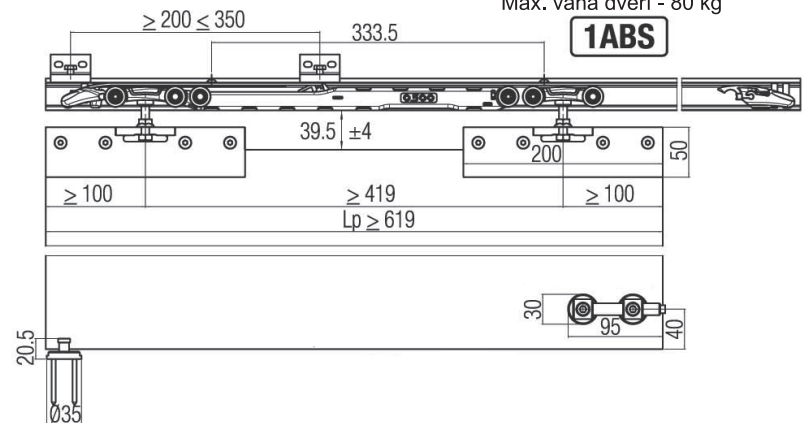
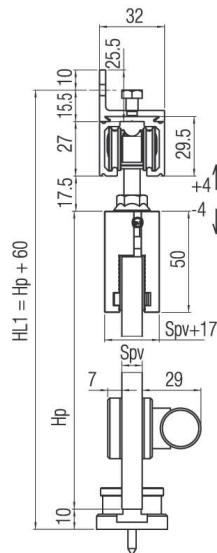

## KOVANIE PRE INTERIÉROVÉ DVERE - 0500

MAX: 120kg / 1 dvere

obj. číslo	špecifikácia
1830	sada kovania 50 kg
1831	sada kovania 80/120kg
1853	profil 2M - 50/80 kg
a183	profil 3M - 50/80 kg
32a1	profil 2M - 120 kg
1836	profil 3M - 120 kg
1839	upínací element - 80 kg
1839-1	upínací element - 120 kg

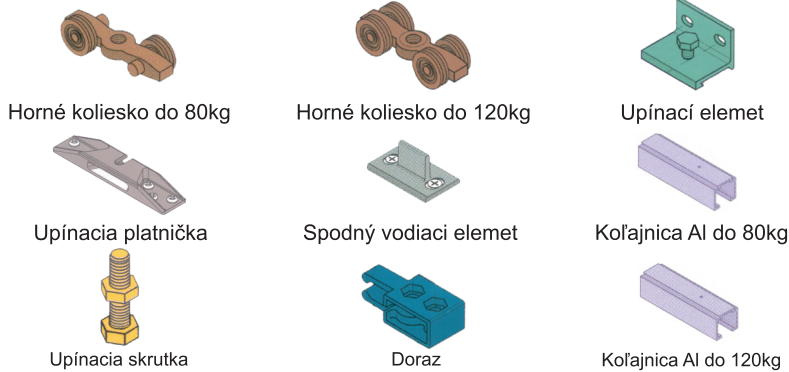
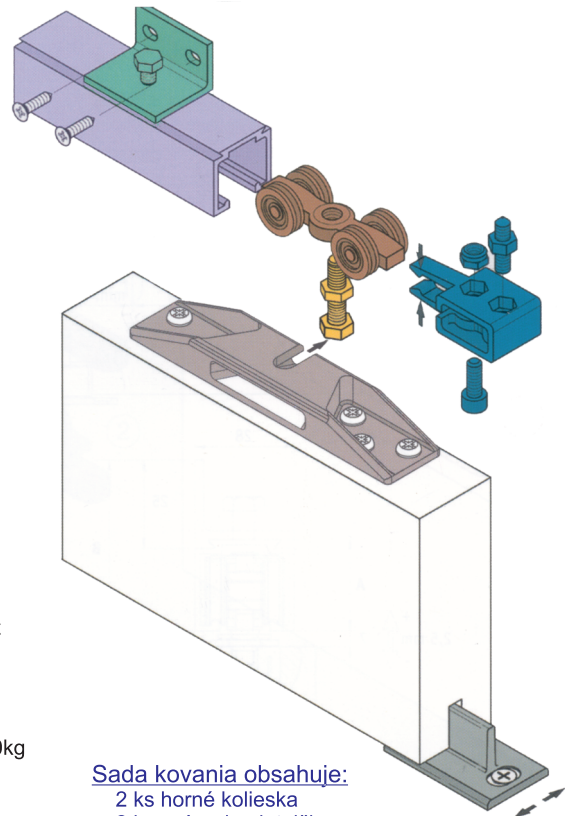

**Sada kovania obsahuje:**  
 2 ks horné kolieska  
 2 ks upínacia platnička  
 2 ks upínacia skrutka  
 2 ks doraz  
 1 ks spodný vodiaci element

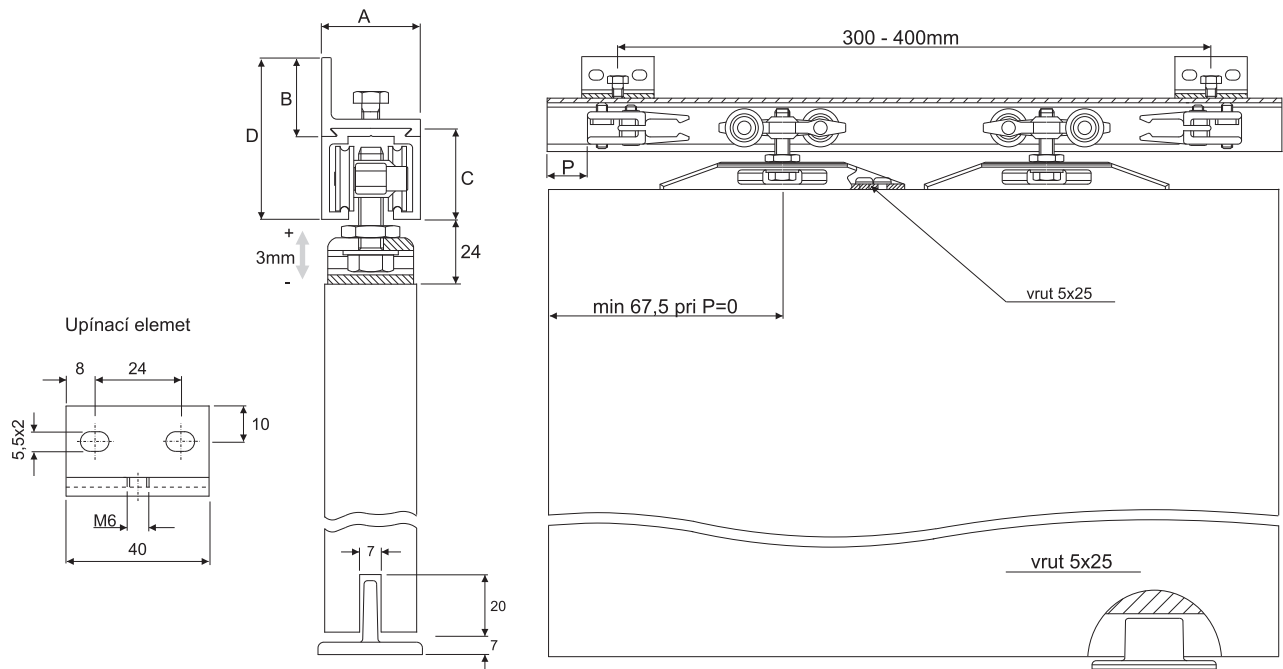

**Príklad vyskladania na požadovanú nosnosť:**

sada na 50 kg dvere - 1830 + 1832  
 sada na 80 kg dvere - 1831 + 1832  
 sada na 120 kg dvere - 1831 + 1835

SYSTÉM	A	B	C	D
0500/50	32	25,5	29,5	52,5
0500/120	33	28	32	56

**KOVANIE PRE INTERIÉROVÉ DVERE SYNCHRÓNNE - 0550**

MAX: 120kg / 1 dvere

obj. číslo	špecifikácia
1831	sada kovania 80/120kg
1832	profil 2M - 50/80 kg
1833	profil 3M - 50/80 kg
1835	profil 2M - 120 kg
1836	profil 3M - 120 kg
1839	upínací element - 80 kg
1839-1	upínací element - 120 kg

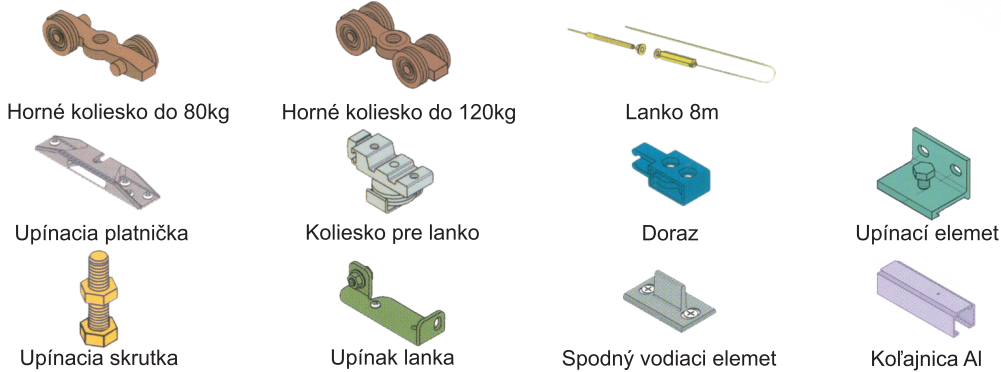
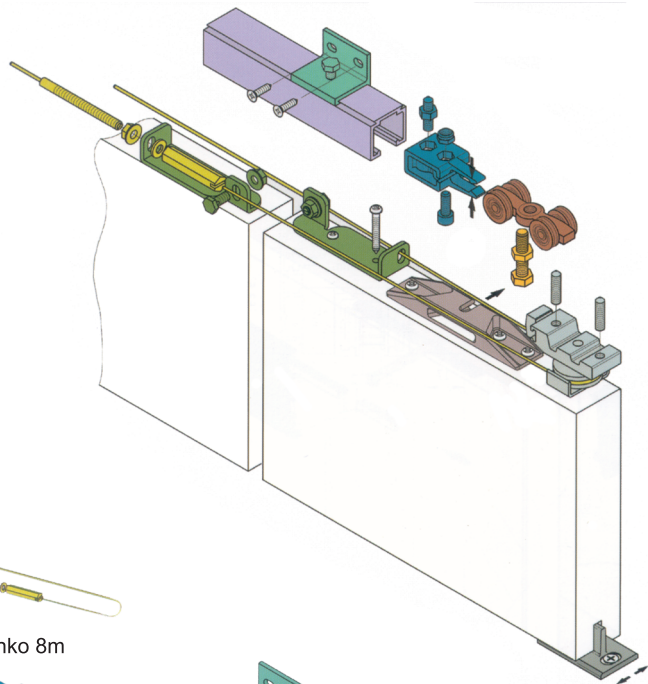

- Sada kovania obsahuje:**
- 4 ks horné kolieska
  - 4 ks upínacia platnička
  - 4 ks upínacia skrutka
  - 1 ks koliesko pre lanko
  - 1 ks upínak lanka
  - 1 ks lanko 8m
  - 2 ks doraz
  - 2 ks spodný vodiaci element
  - spojovací materiál

SYSTÉM	A	B	C	D
0500/50	32	25,5	29,5	52,5
0500/120	33	28	32	56

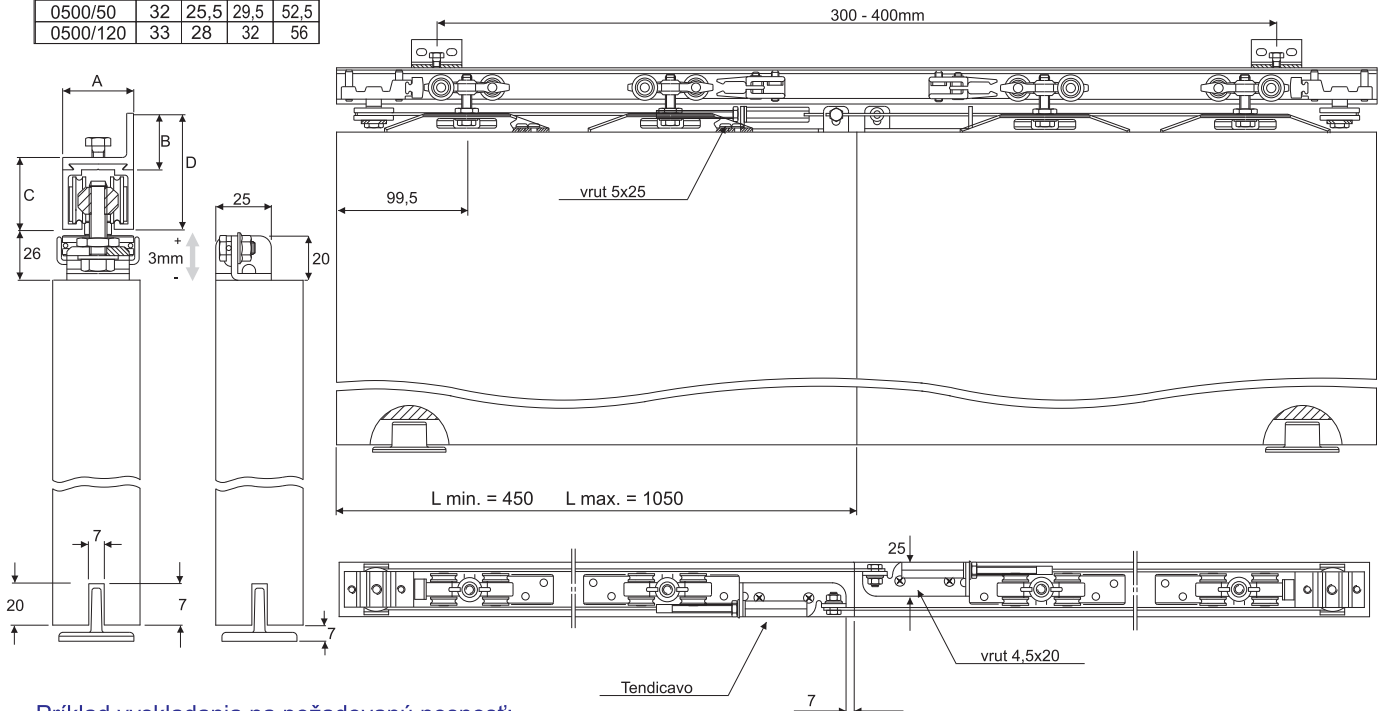

**Príklad vyskladania na požadovanú nosnosť:**

- sada na 50 kg dvere - 1825 + 1832
- sada na 80 kg dvere - 1826 + 1832
- sada na 120 kg dvere - 1826 + 1835



## SADA PRE VYROVNÁVANIE DVERÍ

obj. číslo

58269

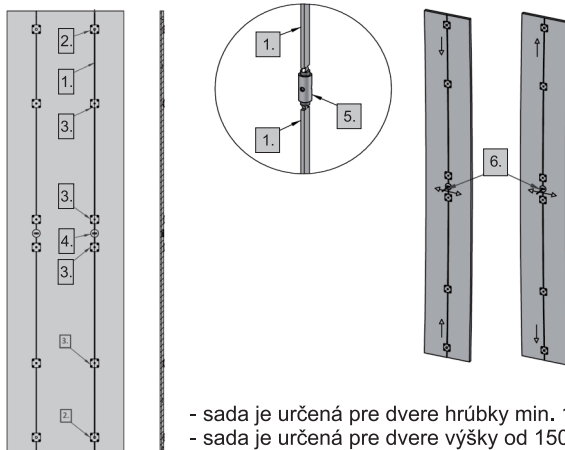

- sada je určená pre dvere hrúbky min. 15mm
- sada je určená pre dvere výšky od 1500 do 2700mm

### VYROVNÁVACIA SADA OBSAHUJE



## PRÍPRAVA SŤAHOVACEJ LIŠTY

- A. Pre dvere o výške 1500-1900mm : skrátit' 350mm
- B. Pre dvere o výške 1900-2300mm : skrátit' 190mm
- C. Pre dvere o výške 2300-2700mm : nie je potrebné skracovať
- D. Frézovanie otvorov pre nafahovacie platničky a pre krytku

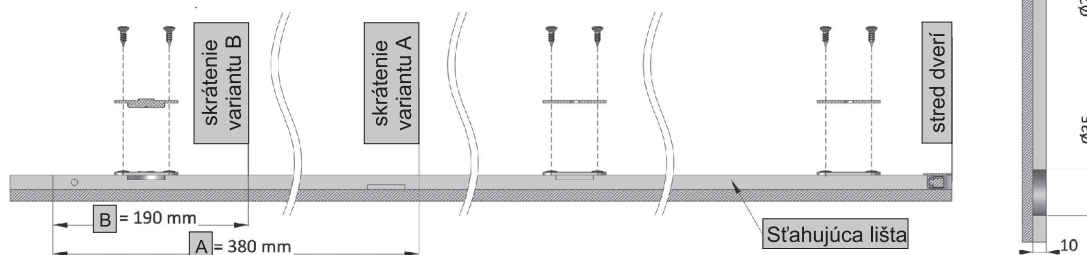

## ZÁMOK PRE POSÚVNE DVERE

obj. číslo

58395-8

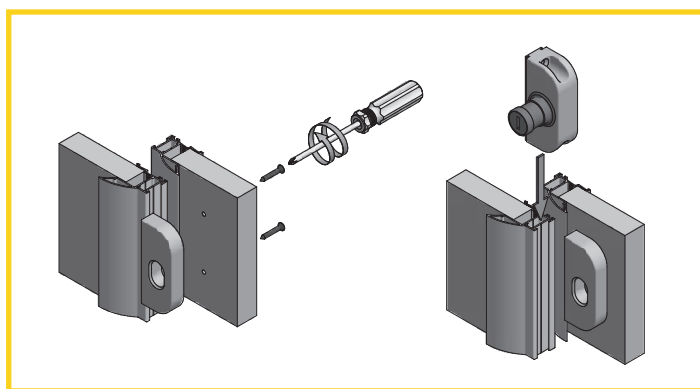
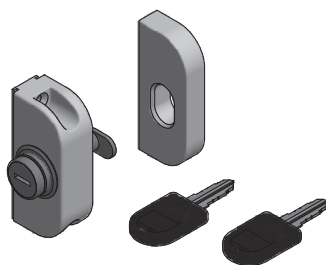

Zámok je možné použiť s profilami:

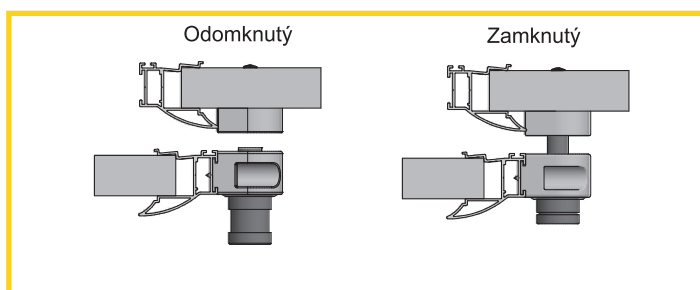

KOVANIE PRE ŠATNÍKOVE DVERE - OVERLINE +

obj. číslo	špecifikácia
58250	sada kovania
58255	spodná koľajnica 405cm
58256	horná koľajnica 405cm
58260	Tlmenie dverí do 25kg
58261	Tlmenie dverí do 40kg
58263	sada pre tlmenie
58263-1	pozicioner

Max. váha dverí: 50 kg  
Hrúbka dverí: 16-22mm

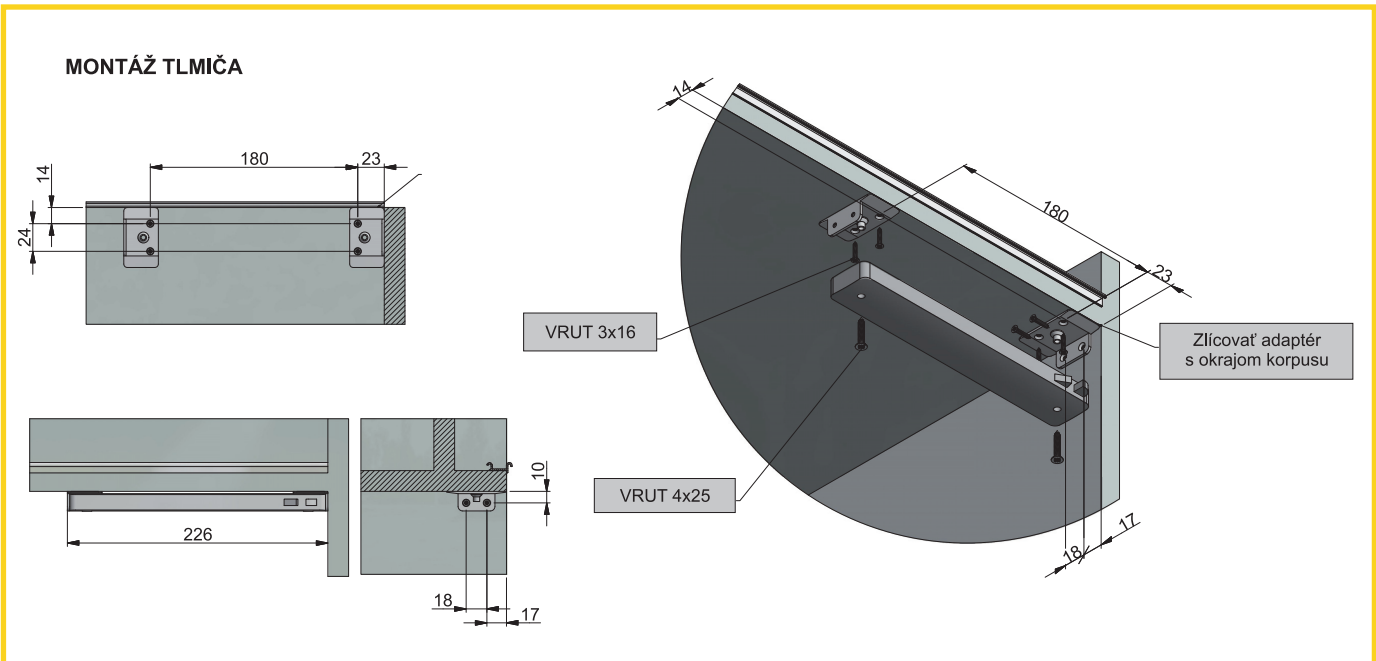
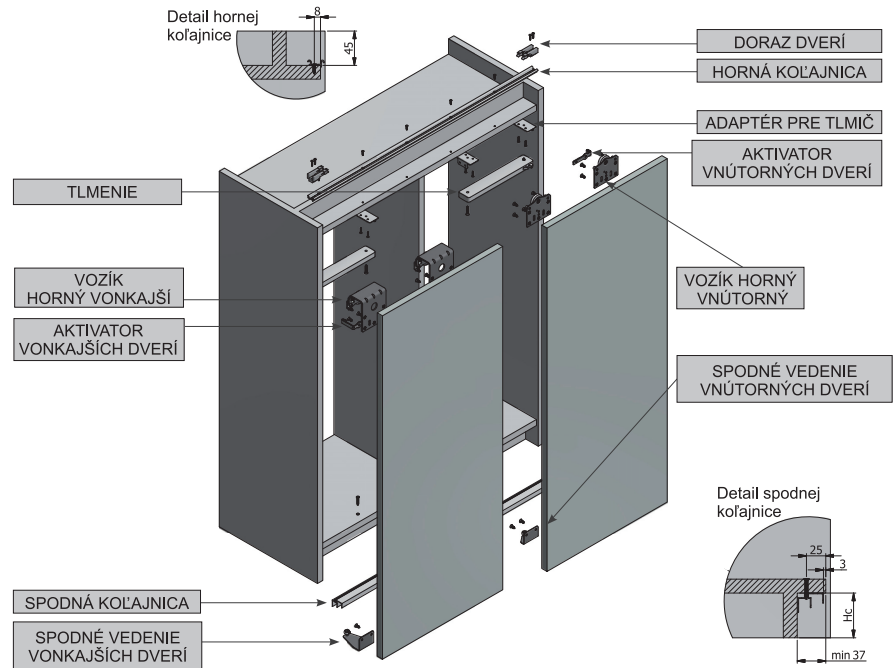
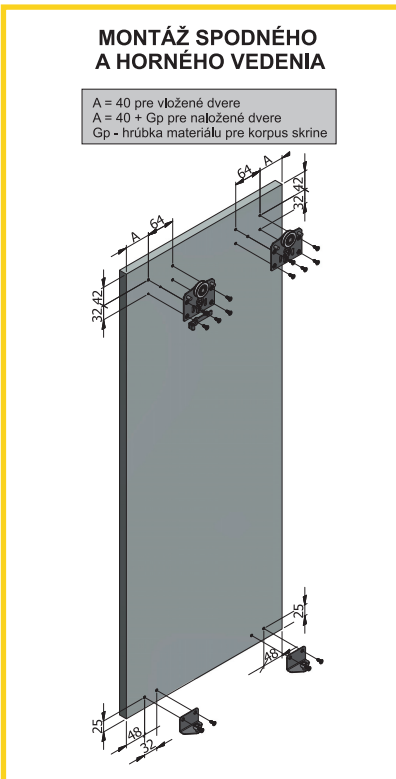

**PROFIL PRE ŠATNÍKOVÉ DVERE - COLLINS CN**

obj. číslo	úprava	dĺžka
<b>58450</b>	strieborná	2,80 M
<b>58450-1</b>	strieborná	3,10 M
<b>58459</b>	šampaň	2,80 M
<b>58459-5</b>	čierna matná	2,80 M

obj. číslo	špecifikácia
<b>5855</b>	koliesko spodné
<b>5855-8</b>	koliesko horné
<b>5866-6</b>	štetina dorazová šedá
<b>5866-8</b>	štetina dorazová čierna
<b>58389</b>	štetina prechodová

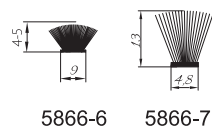

5866-6 5866-7

Výpočet rozmerov dverí a výplne pre profil COLLINS

$S_d$	$= (S_v + 2 \times P_d) : 3$
$L_p$	$=$ svetla výška - 35mm
$L_s$	$= S_d - 48mm$
$V_1$	$= L_p - 60mm$
$V_2$	$= L_p - 62mm$
$S_1$	$= S_d - 32mm$
$S_2$	$= S_d - 35mm$
$V_{d2}$	$= (L_p - 61) : 2$
$V_{d3}$	$= (L_p - 62) : 3$

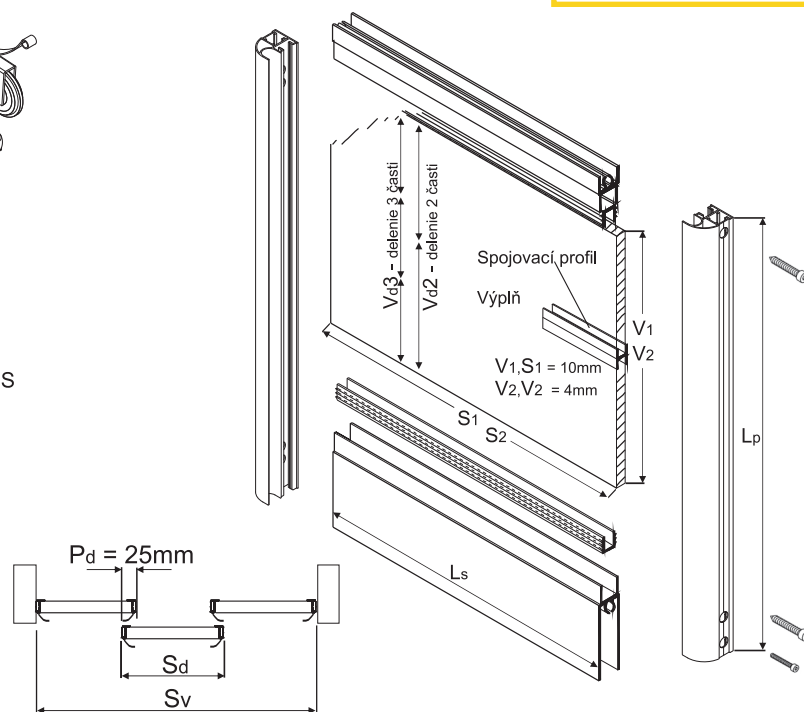
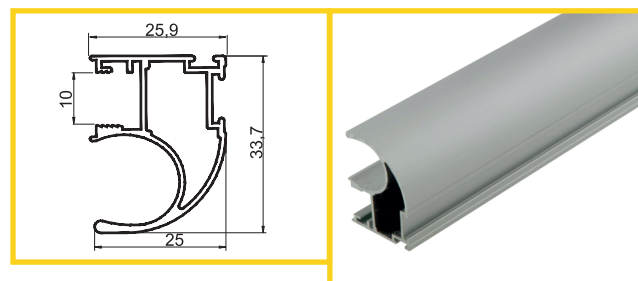
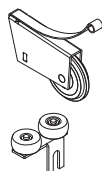

**PROFIL PRE ŠATNÍKOVÉ DVERE - DALLAS CN**

obj. číslo	úprava	dĺžka
<b>58457</b>	strieborná	2,80 M
<b>58458</b>	šampaň	2,80 M

obj. číslo	špecifikácia
<b>5855</b>	koliesko spodné
<b>5855-8</b>	koliesko horné
<b>5866-6</b>	štetina dorazová nasúvacia
<b>5866-2</b>	štetina prechodová lepiaca

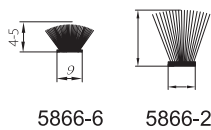

5866-6 5866-2

Výpočet rozmerov dverí a výplne pre profil DALLAS

$S_d$	$= (S_v + 2 \times P_d) : 3$
$L_p$	$=$ svetla výška - 35mm
$L_s$	$= S_d - 48mm$
$V_1$	$= L_p - 60mm$
$V_2$	$= L_p - 62mm$
$S_1$	$= S_d - 32mm$
$S_2$	$= S_d - 35mm$
$V_{d2}$	$= (L_p - 61) : 2$
$V_{d3}$	$= (L_p - 62) : 3$

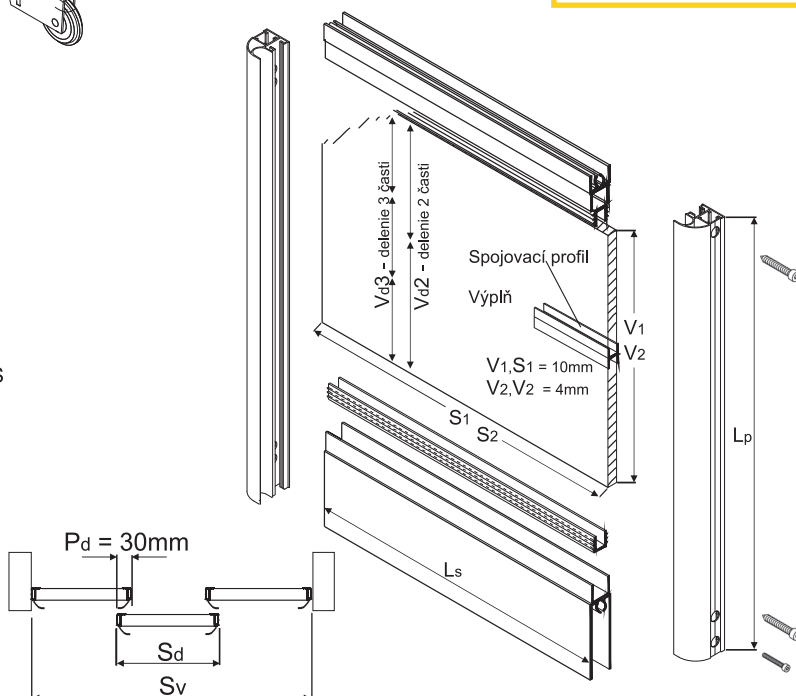
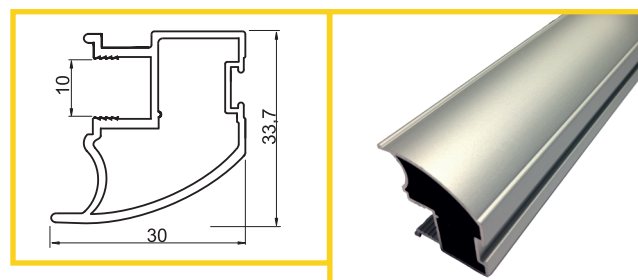
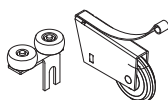

**PROFIL PRE ŠATNÍKOVÉ DVERE - KVADRAT CN**

obj. číslo	úprava	dĺžka
<b>58451</b>	strieborná	2,80 M
<b>58451-1</b>	šampaň	2,80 M

obj. číslo	špecifikácia
<b>5855</b>	koliesko spodné
<b>5855-6</b>	koliesko horné
<b>5866-6</b>	štetina dorazová nasúvacia
<b>5866-2</b>	štetina prechodová lepiaca

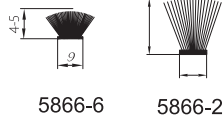
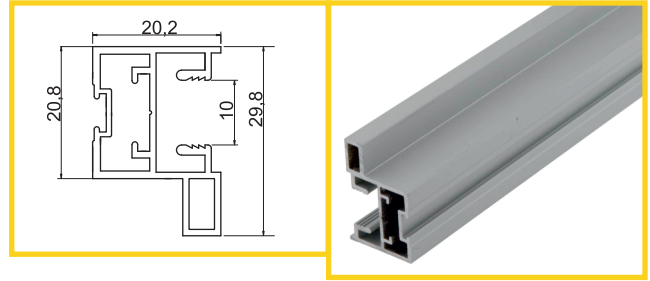
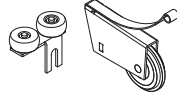

Výpočet rozmerov dverí a výplne pre profil KVADRAT

$S_d$	=	$(S_v + 2 \times P_d) : 3$
$L_p$	=	svetla výška - 35mm
$L_s$	=	$S_d - 38mm$
$V_1$	=	$L_p - 60mm$
$V_2$	=	$L_p - 62mm$
$S_1$	=	$S_d - 20mm$
$S_2$	=	$S_d - 17mm$
$V_{d2}$	=	$(L_p - 61) : 2$
$V_{d3}$	=	$(L_p - 62) : 3$

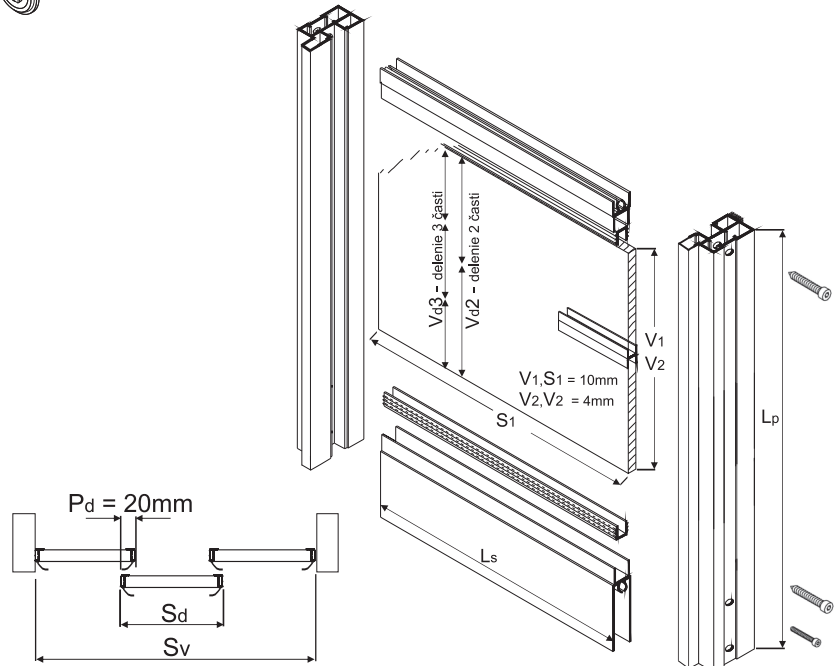

**PROFIL PRE ŠATNÍKOVÉ DVERE - KVADRAT PLUS CN**

obj. číslo	úprava	dĺžka
<b>58452</b>	strieborná	2,80 M
<b>58452-1</b>	šampaň	2,80 M
<b>58452-5</b>	čierny matný	2,80 M

obj. číslo	špecifikácia
<b>5855</b>	koliesko spodné
<b>5855-8</b>	koliesko horné
<b>5866-6</b>	štetina dorazová šedá
<b>5866-8</b>	štetina dorazová čierna

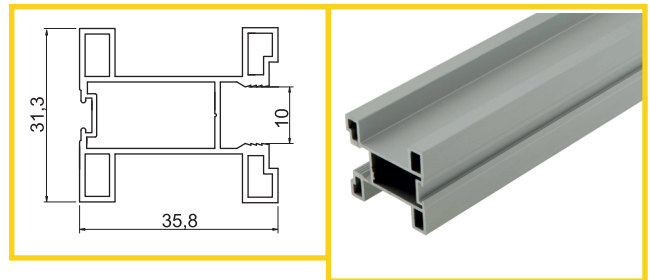
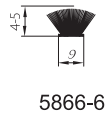

Výpočet rozmerov dverí a výplne pre profil KVADRAT PLUS

$S_d$	=	$(S_v + 2 \times P_d) : 3$
$L_p$	=	svetla výška - 35mm
$L_s$	=	$S_d - 68mm$
$V_1$	=	$L_p - 60mm$
$V_2$	=	$L_p - 64mm$
$S_1$	=	$S_d - 50mm$
$S_2$	=	$S_d - 47mm$
$V_{d2}$	=	$(L_p - 61) : 2$
$V_{d3}$	=	$(L_p - 62) : 3$

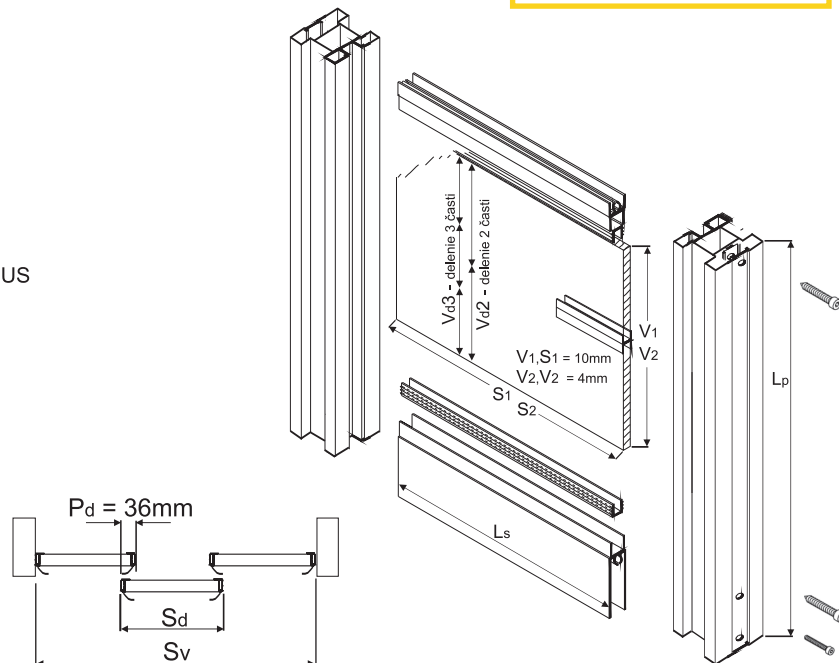

**PROFIL PRE ŠATNÍKOVÉ DVERE - OTTAWA CN**

obj. číslo	úprava	dĺžka
<b>58454</b>	strieborná	2,80 M
<b>58458</b>	šampaň	2,80 M

obj. číslo	špecifikácia
<b>5855</b>	koliesko spodné
<b>5855-5</b>	koliesko horné
<b>5866-6</b>	štetina dorazová nasúvacia
<b>5866-2</b>	štetina prechodová lepiaca

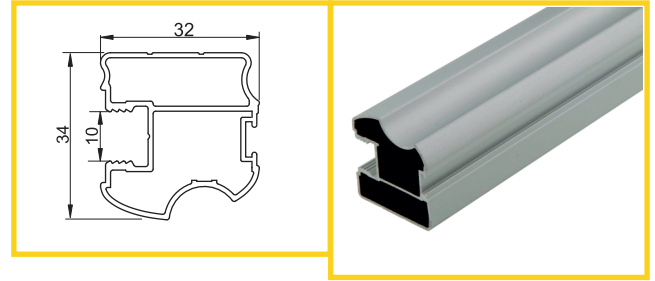
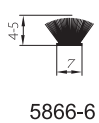

Sd	=	( Sv + 2 x Pd ) : 3
Lp	=	svetla výška - 35mm
Ls	=	Sd - 60mm
V1	=	Lp - 60mm
V2	=	Lp - 62mm
S1	=	Sd - 44mm
S2	=	Sd - 41mm
Vd2	=	( Lp - 61 ) : 2
Vd3	=	( Lp - 62 ) : 3

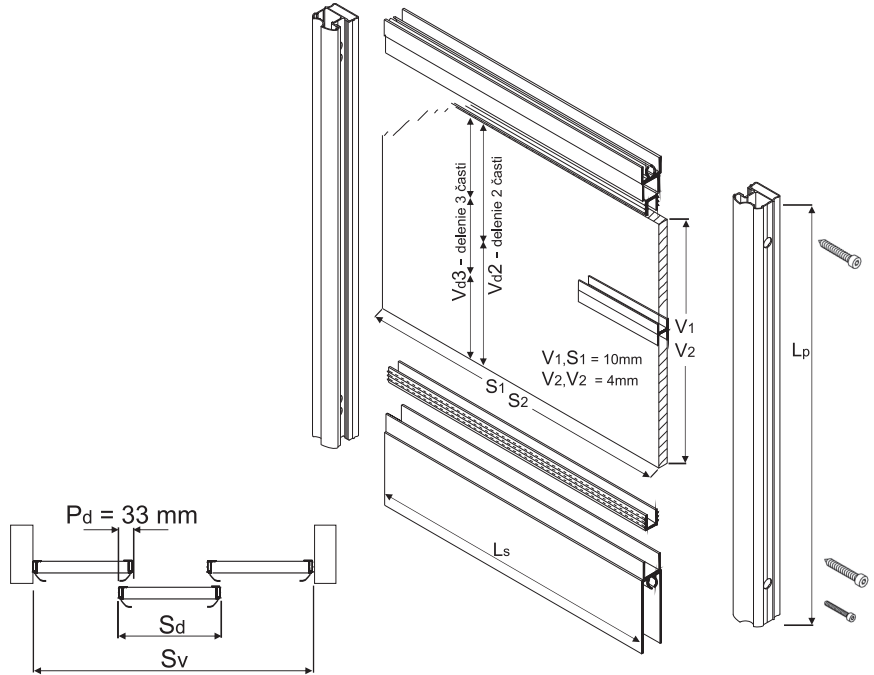

**PROFIL PRE ŠATNÍKOVÉ DVERE - NOVO**

obj. číslo	úprava	dĺžka
<b>58449</b>	strieborná	2,70 M
<b>58448</b>	šampaň	2,70 M
<b>58447</b>	biely	2,70 M
<b>58449-1</b>	čierny mat	2,70 M

obj. číslo	špecifikácia
<b>5855</b>	koliesko spodné
<b>5855-6</b>	koliesko horné
<b>58385</b>	štetina nasúvacia šedá
<b>5866-2</b>	štetina prechodová lepiaca

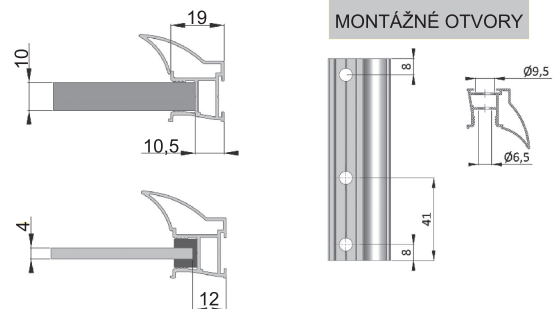
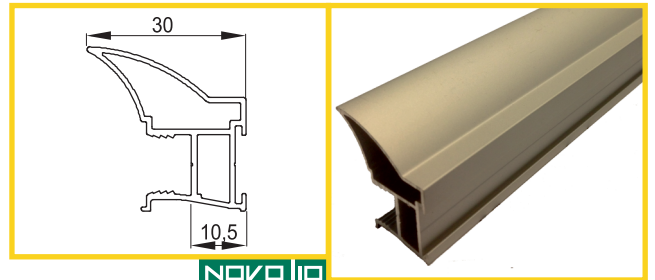
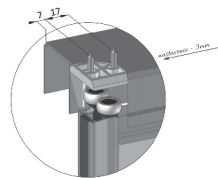
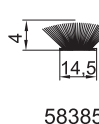

Sd - šírka dverí	=	( Sv + 2 x Pd ) : 3
Lp - výška dverí	=	svetla výška - 35mm
Ls - dĺžka spojovačky	=	Sd - 38mm
V1 - výška výplne ( DTD )	=	Lp - 60mm
V2 - výška výplne ( sklo )	=	Lp - 62mm
S1 - šírka výplne ( DTD )	=	Sd - 21mm
S2 - šírka výplne ( sklo )	=	Sd - 24mm

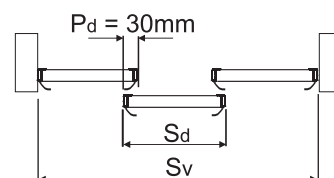

\* Výška výplne delených dverí : výpočet rovnako ako pri profile COLLINS

## PROFIL PRE ŠATNÍKOVÉ DVERE - FALDA

obj. číslo	úprava	dĺžka
58440	strieborná	2,70 M
58441	šampaň	2,70 M

obj. číslo	špecifikácia
5855	koliesko spodné
5855-5	koliesko horné
58385	štetina nasúvacia dorazová

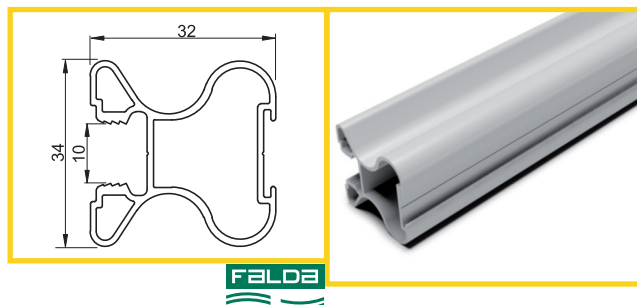

FALDA

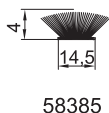

58385

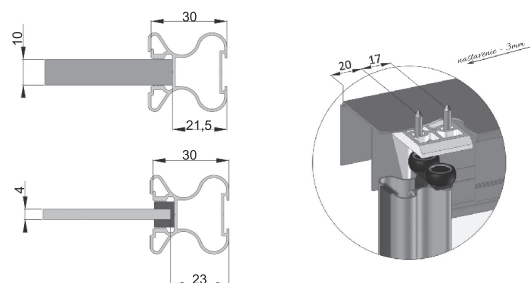

S <sub>d</sub> - šírka dverí	=	(S <sub>v</sub> + 2 x P <sub>d</sub> ) : 3
L <sub>p</sub> - výška dverí	=	svetla výška - 35mm
L <sub>s</sub> - dĺžka spojovačky	=	S <sub>d</sub> - 60mm
V <sub>1</sub> - výška výplne ( DTD )	=	L <sub>p</sub> - 60mm
V <sub>2</sub> - výška výplne ( sklo )	=	L <sub>p</sub> - 62mm
S <sub>1</sub> - šírka výplne ( DTD )	=	S <sub>d</sub> - 43mm
S <sub>2</sub> - šírka výplne ( sklo )	=	S <sub>d</sub> - 46mm

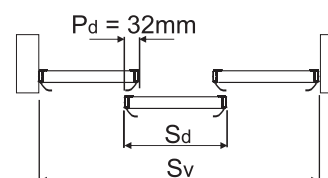

\* **Výška výplne delených dverí** : výpočet rovnako ako pri profile COLLINS

## PROFIL PRE ŠATNÍKOVÉ DVERE - ARCO

obj. číslo	úprava	dĺžka
58442	strieborná	2,70 M
58443	šampaň	2,70 M

obj. číslo	špecifikácia
5855	koliesko spodné
5855-5	koliesko horné
58385	štetina nasúvacia dorazová

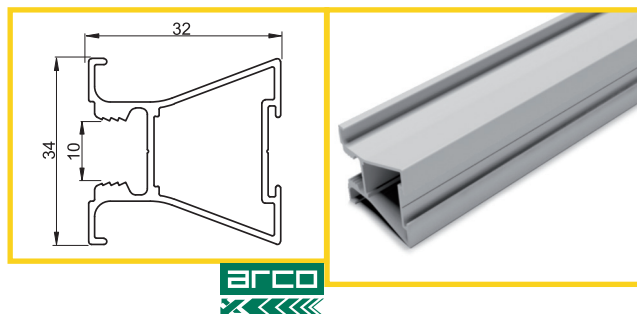

ARCO

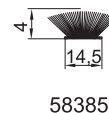

58385

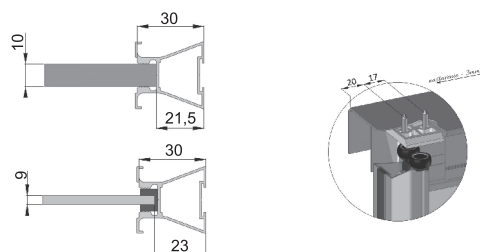

S <sub>d</sub> - šírka dverí	=	(S <sub>v</sub> + 2 x P <sub>d</sub> ) : 3
L <sub>p</sub> - výška dverí	=	svetla výška - 35mm
L <sub>s</sub> - dĺžka spojovačky	=	S <sub>d</sub> - 38mm
V <sub>1</sub> - výška výplne ( DTD )	=	L <sub>p</sub> - 60mm
V <sub>2</sub> - výška výplne ( sklo )	=	L <sub>p</sub> - 62mm
S <sub>1</sub> - šírka výplne ( DTD )	=	S <sub>d</sub> - 43mm
S <sub>2</sub> - šírka výplne ( sklo )	=	S <sub>d</sub> - 46mm

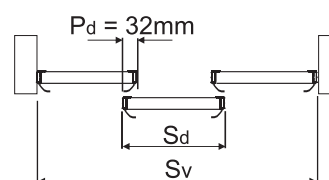

\* **Výška výplne delených dverí** : výpočet rovnako ako pri profile COLLINS

## SPOJOVACÍ SPODNÝ PROFIL

obj. číslo	dĺžky profilov	úprava
<b>5840-9</b>	2.0M, 3.0M, 4.0M,	strieborná
<b>5840-1</b>	2.0M, 3.0M, 4.0M,	šampaň
<b>5840-5</b>	3.0M	čierna matná

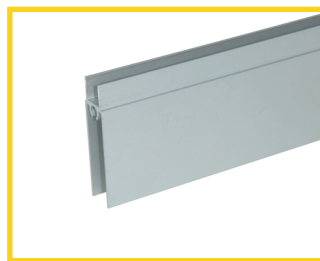
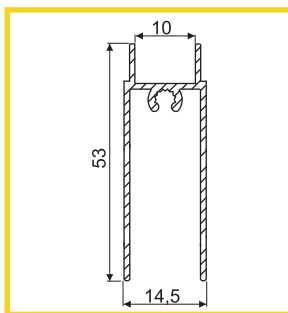

## SPOJOVACÍ HORNÝ PROFIL

obj. číslo	dĺžky profilov	úprava
<b>5841-9</b>	2.0M, 3.0M, 4.0M	strieborná
<b>5841-1</b>	2.0M, 3.0M, 4.0M	šampaň
<b>5841-5</b>	3.0M	čierna matná

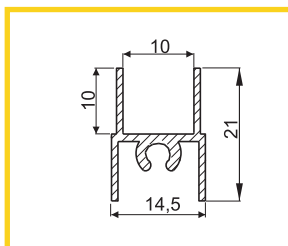

## SPOJOVACÍ DELIACI PROFIL

obj. číslo	dĺžky profilov	úprava
<b>5842-9</b>	2.0M, 3.0M, 4.0M	strieborná
<b>5842-1</b>	2.0M, 3.0M, 4.0M	šampaň
<b>5842-5</b>	3.0M	čierna matná

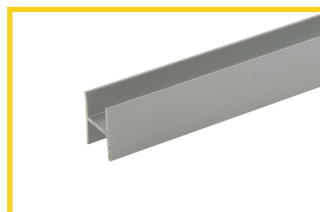
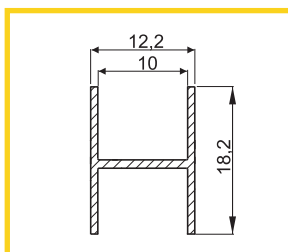

## SPODNÁ DVOJKOLAJNICA

obj. číslo	dĺžky profilov	úprava
<b>5846-9</b>	2.0M, 3.0M, 4.0M, 6.0M	strieborná
<b>5846-1</b>	2.0M, 3.0M, 4.0M, 6.0M	šampaň
<b>5846-5</b>	3.0M, 4.0M, 6.0M	čierna matná

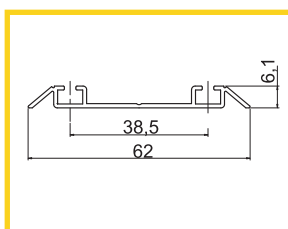

## HORNÁ DVOJKOLAJNICA

obj. číslo	dĺžky profilov	úprava
<b>5847-9</b>	2.0M, 3.0M, 4.0M, 6.0M	strieborná
<b>5847-1</b>	2.0M, 3.0M, 4.0M, 6.0M	šampaň
<b>5847-5</b>	3.0M, 4.0M, 6.0M	čierna matná

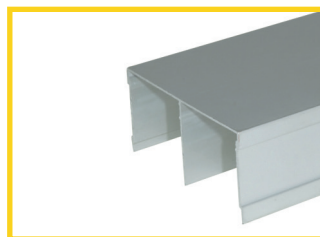
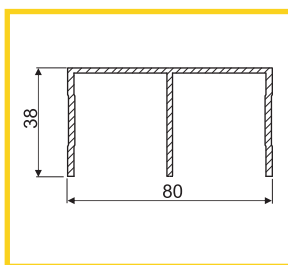

## SPODNÁ JEDNOKOLAJNICA

obj. číslo	dĺžky profilov	úprava
<b>5848-9</b>	2.0M, 3.0M, 4.0M, 6.0M	strieborná
<b>5848-1</b>	2.0M, 3.0M, 4.0M, 6.0M	šampaň
<b>5848-5</b>	2.0M, 3.0M, 4.0M, 6.0M	čierna matná

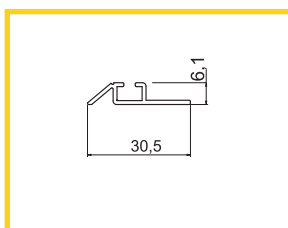

## HORNÁ JEDNOKOLAJNICA

obj. číslo	dĺžky profilov	úprava
<b>5849-9</b>	2.0M, 3.0M, 4.0M, 6.0M	strieborná
<b>5849-1</b>	2.0M, 3.0M, 4.0M, 6.0M	šampaň
<b>5849-5</b>	2.0M, 3.0M, 4.0M, 6.0M	čierna matná

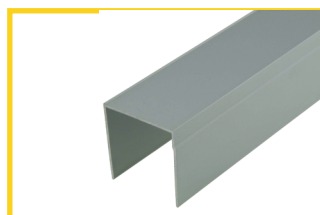
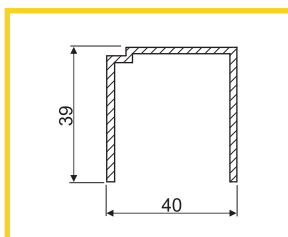

## PROFIL PRE ŠATNÍKOVÉ DVERE - ERGO

obj. číslo	úprava	dĺžka
<b>58330</b>	strieborná	2,70 M
<b>58331</b>	šampaň	2,70 M

ERGO 18 PRO

obj. číslo	špecifikácia
<b>5855-7</b>	koliesko 1 spodné + 1 horné
<b>58386</b>	štetina dorazová nasávací
<b>5866-2</b>	štetina prechodová lepiaca
<b>5854-1</b>	brzda do spodnej koľajnice
<b>58388</b>	brzda do hornej koľajnice

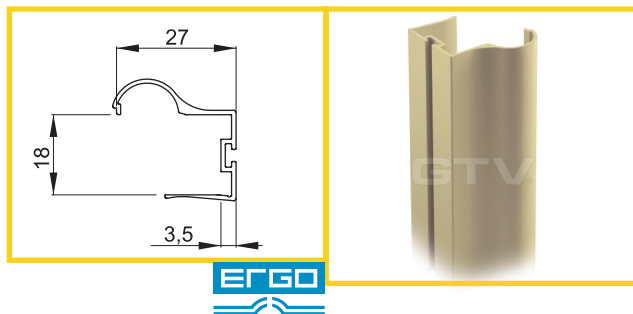

**ERGO**

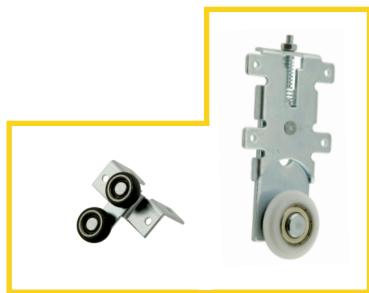

Výpočet rozmerov dverí a výplne pre profil ERGO

Sd	= ( Sv + 2 x Pd ) : 3
Lp	= svetla výška - 40mm
V1	= Lp
S1	= Sd - 7mm

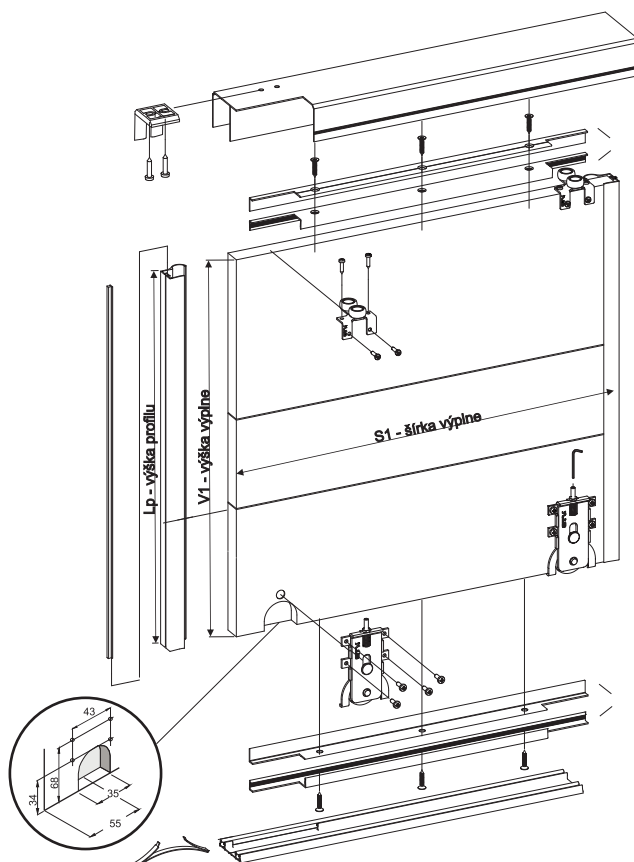
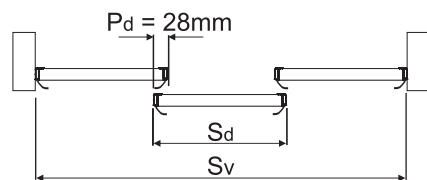

### UKONČOVACÍ PROFIL „L“

obj. číslo	špecifikácia
<b>58365</b>	strieborná - 3M
<b>58366</b>	šampaň - 3M
<b>58365-5</b>	biely - 3M
<b>58365-6</b>	čierny - 3M

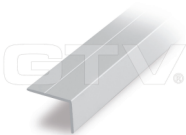

Pri použití ukončovacieho profilu „L“ : V1 - 3mm

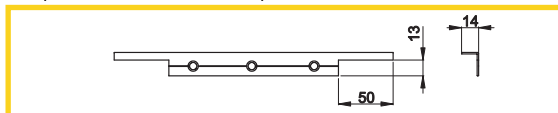

### UKONČOVACÍ PROFIL „U“

obj. číslo	špecifikácia
<b>58368</b>	strieborná - 3M
<b>58369</b>	šampaň - 3M
<b>58368-5</b>	biely - 3M
<b>58368-6</b>	čierny - 3M

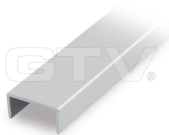

Pri použití ukončovacieho profilu „U“ : V1 - 3mm

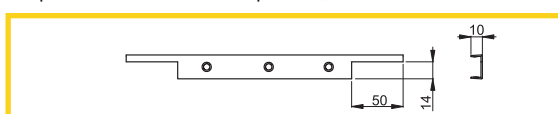

Dĺžka vodorovných profilov = Sd - 54mm

### PREDEĽOVACÍ PROFIL „H“

obj. číslo	špecifikácia
<b>58362</b>	strieborná - 3M
<b>58363</b>	šampaň - 3M

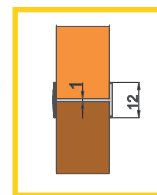

### PREDEĽOVACÍ PROFIL „T“

obj. číslo	špecifikácia
<b>58370</b>	strieborná - 3M
<b>58371</b>	šampaň - 3M

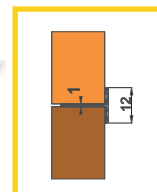



PROFIL PRE ŠATNÍKOVÉ DVERE - NOVO-S

obj. číslo	úprava	dĺžka
58333	strieborná	2,70 M
58334	šampaň	2,70 M
58334-1	biela	2,70 M
58334-2	čierna	2,70 M

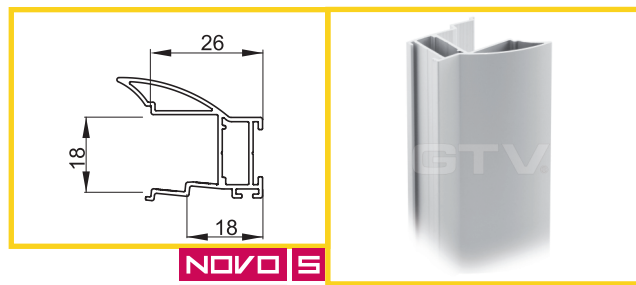

obj. číslo	špecifikácia
5855-7	Koliesko 1 spodné + 1 horné
58385	štetina dorazová nasúvacia
58387	štetina BIELA dorazová
58387-5	štetina ČIERNA dorazová
5866-7	štetina prechodová nasúvacia
5854-1	brzda do spodnej koľajnice
58388	brzda do horej koľajnice

Výpočet rozmerov dverí a výplne pre profil NOVO

Sd	= ( Sv + 2 x Pd ) : 3
Lp	= svetla výška - 40mm
V1	= Lp
S1	= Sd - 36mm

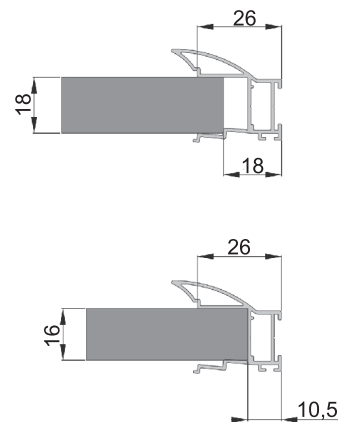
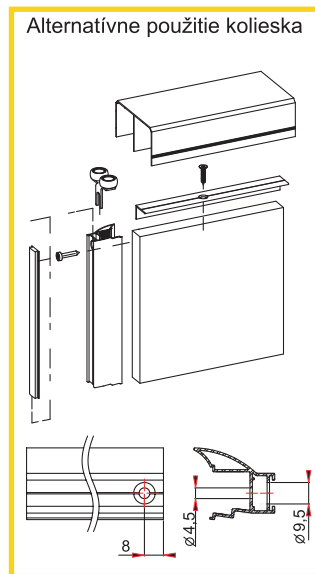
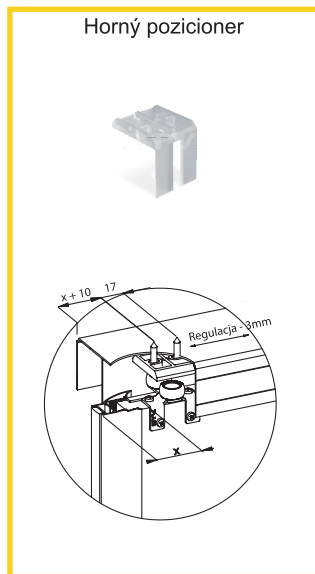
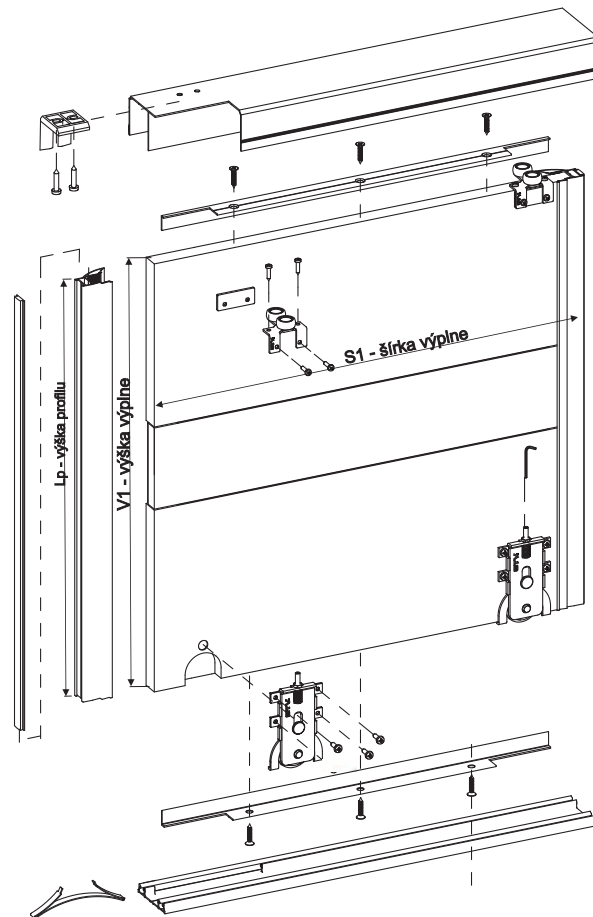
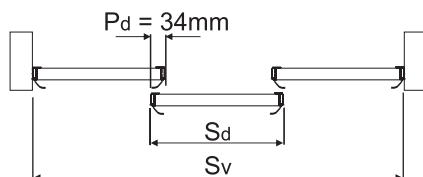

**PROFIL PRE ŠATNÍKOVÉ DVERE - NOVO-S**

obj. číslo	úprava	dĺžka
<b>58333</b>	strieborná	2,70 M
<b>58334</b>	šampaň	2,70 M
<b>58334-1</b>	biela	2,70 M
<b>58334-2</b>	čierna	2,70 M



obj. číslo	špecifikácia
<b>58393</b>	koliesko spodné
<b>5855-6</b>	koliesko horné
<b>58385</b>	štetina dorazová nasúvacia
<b>58389</b>	štetina prechodová nasúvacia
<b>58387</b>	štet. BIELA dorazová nasúv.
<b>58387-5</b>	štet. ČIERNA dorazová
<b>5854-1</b>	brzda do spodnej koľajnice
<b>58388</b>	brzda do hornej koľajnice
<b>58390</b>	kĺn do bočného profilu
<b>58391</b>	kĺn do spojovacieho profilu

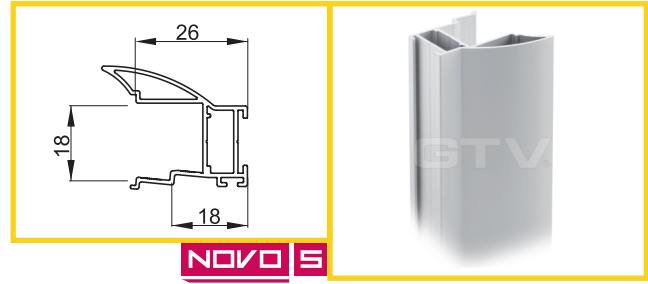

**NOVO S**

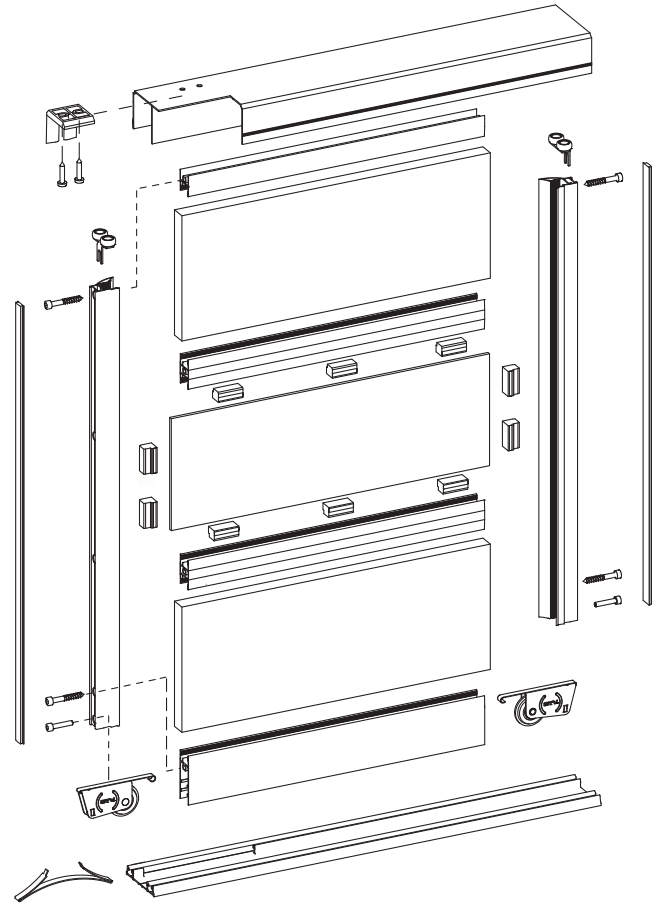

Výpočet rozmerov dverí a výplne pre profil NOVO

Šírka dverí	Sd	= ( Sv + 2 x Pd ) : 3
Výška dverí	Lp	= svetla výška - 40mm
Výška výplne		= Lp - 69mm
Výška výplne sklo		= Lp - 61mm
Šírka výplne		= Sd - 36mm
Šírka výplne sklo		= Sp - 24mm
Dĺžka „H“ profilu		= Sd - 52mm

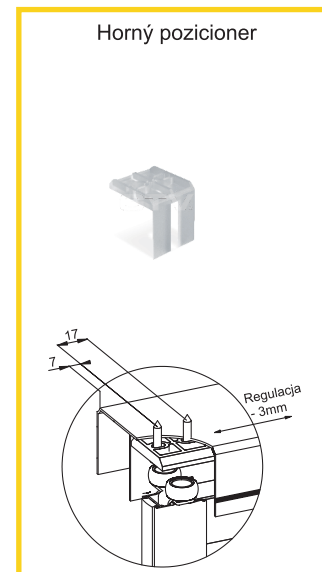
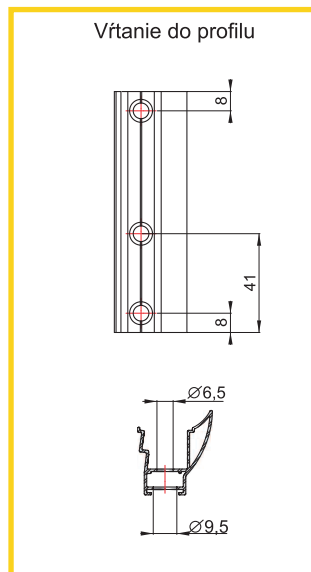
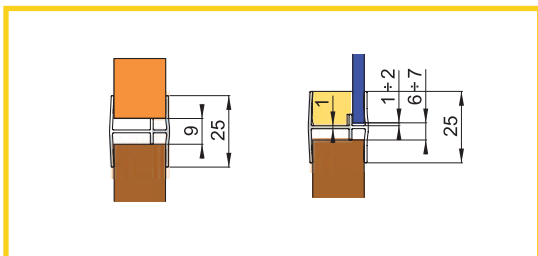
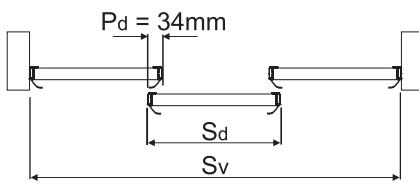

### PROFIL PRE ŠATNÍKOVÉ DVERE - COTE

obj. číslo	úprava	dĺžka
<b>58335-5</b>	strieborná	2,70 M
<b>58335-6</b>	šampaň	2,70 M

Výpočet šírky dverí a výplne

Šírka dverí	Sd	= ( Sv + 2 x Pd ) : 3
Šírka výplne		= Sd - 36mm
Šírka výplne sklo		= Sd - 23mm
Dĺžka „H“ profilu		= Sd - 52mm

Výška dverí a výplne sa počíta rovnako ako pri profile NOVO-S

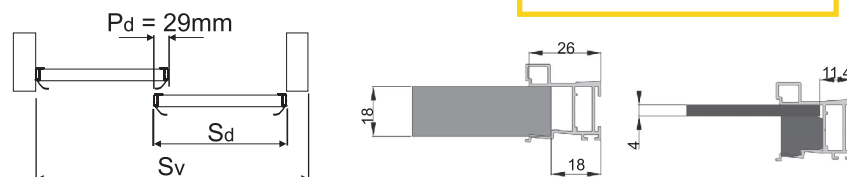
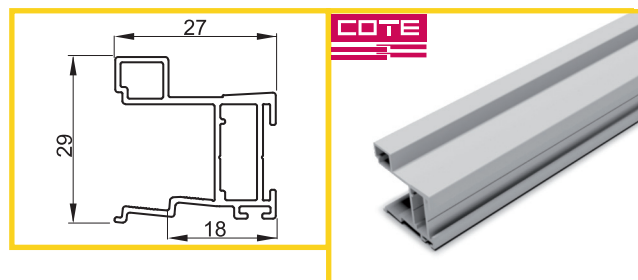

### PROFIL PRE ŠATNÍKOVÉ DVERE - VISTA

obj. číslo	úprava	dĺžka
<b>58335-1</b>	strieborná	2,70 M
<b>58335-2</b>	šampaň	2,70 M

Šírka dverí	Sd	= ( Sv + 2 x Pd ) : 3
Šírka výplne		= Sd - 31mm
Šírka výplne sklo		= Sd - 23mm
Dĺžka „H“ profilu		= Sd - 55mm

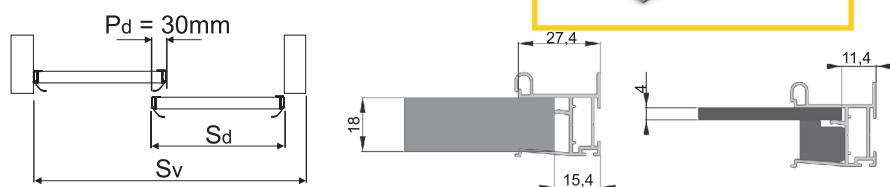
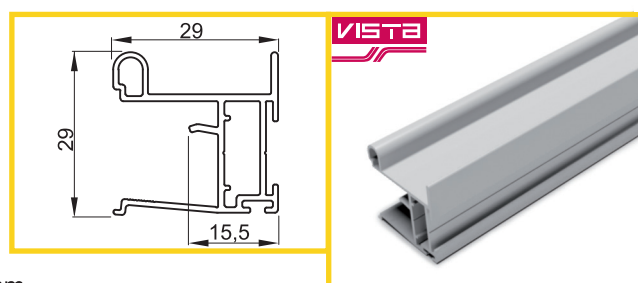

### PROFIL PRE ŠATNÍKOVÉ DVERE - NERO

obj. číslo	úprava	dĺžka
<b>58336-5</b>	strieborná	2,70 M
<b>58336-6</b>	šampaň	2,70 M
<b>58336-8</b>	biela	2,70 M
<b>58336-9</b>	čierna	2,70 M

Šírka dverí	Sd	= ( Sv + 2 x Pd ) : 3
Šírka výplne		= Sd - 31mm
Šírka výplne sklo		= Sd - 23mm
Dĺžka „H“ profilu		= Sd - 55mm

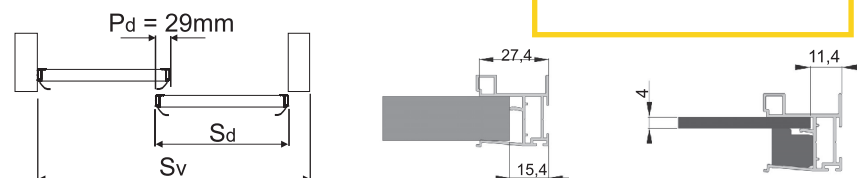
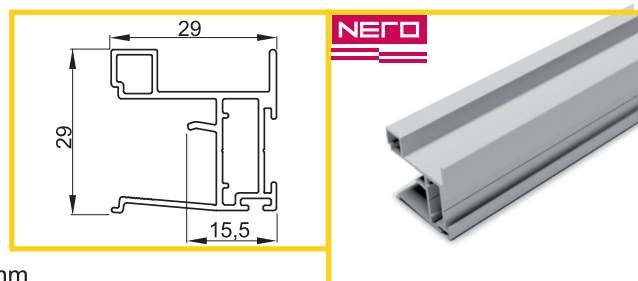

### PROFIL PRE ŠATNÍKOVÉ DVERE - CARO

obj. číslo	úprava	dĺžka
<b>58336-1</b>	strieborná	2,70 M
<b>58336-2</b>	šampaň	2,70 M

Šírka dverí	Sd	= ( Sv + 2 x Pd ) : 3
Šírka výplne		= Sd - 31mm
Šírka výplne sklo		= Sd - 23mm
Dĺžka „H“ profilu		= Sd - 55mm

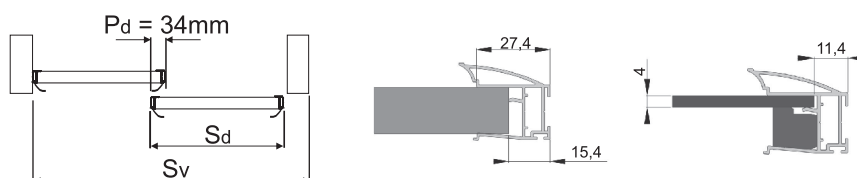
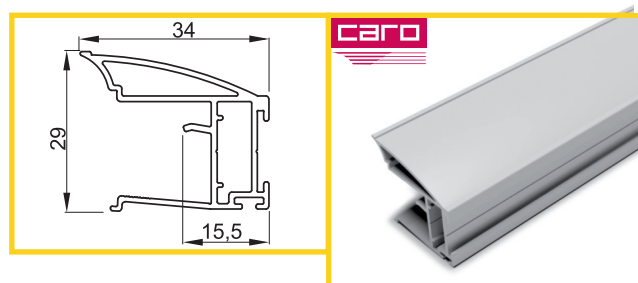

## SPOJOVACIE VODOROVNÉ PROFILY

### SPODNÝ

obj. číslo	úprava	dĺžka
<b>58342</b>	strieborná	3,00 M
<b>58341</b>	strieborná	4,00 M
<b>58345</b>	šampaň	2,35 M
<b>58346</b>	šampaň	4,05 M
<b>58341-5</b>	biely	3,00 M
<b>58341-7</b>	čierny	3,00 M

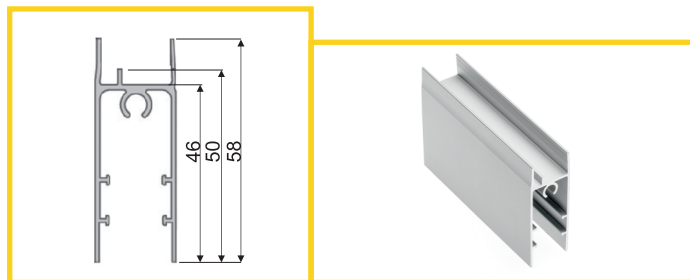

### HORNÝ

obj. číslo	úprava	dĺžka
<b>58352</b>	strieborná	3,00 M
<b>58351</b>	strieborná	4,00 M
<b>58355</b>	šampaň	2,35 M
<b>58356</b>	šampaň	4,00 M
<b>58351-5</b>	biela	3,00 M
<b>58351-7</b>	čierna	3,00 M

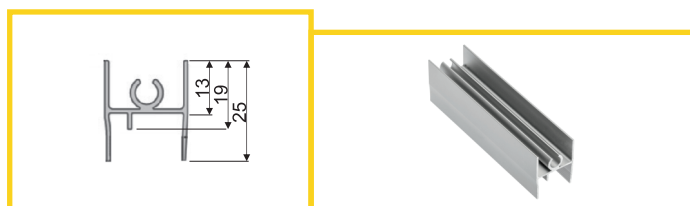

### PREDEĽOVACÍ

obj. číslo	úprava	dĺžka
<b>58360</b>	strieborná	3,00 M
<b>58361</b>	šampaň	3,00 M
<b>58361-5</b>	biela	3,00 M
<b>58361-7</b>	čierna	3,00 M

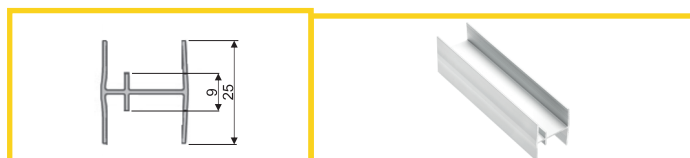

## KOĽAJNICE

### SPODNA KOĽAJNICA „EVO“

obj. číslo	úprava	dĺžka
<b>58370</b>	strieborná	2,00 M
<b>58371</b>	strieborná	3,00 M
<b>58372</b>	strieborná	4,00 M
<b>58373</b>	strieborná	6,00 M

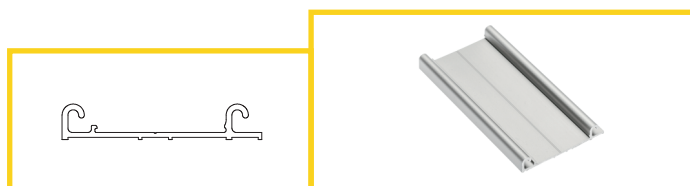

### SPODNA KOĽAJNICA „PRO“

obj. číslo	špecifikácia	dĺžka
<b>58373-7</b>	strieborná	2,00 M
<b>58373-8</b>	strieborná	3,00 M
<b>58373-9</b>	strieborná	4,00 M
<b>58373-10</b>	strieborná	6,00 M
<b>58371-3</b>	biela	3,00 M
<b>58371-4</b>	biela	4,05 M
<b>58371-7</b>	čierna	3,00 M
<b>58371-8</b>	čierna	4,05 M

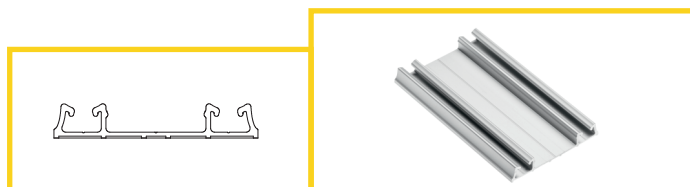

### HORNÁ KOĽAJNICA EVO

obj. číslo	úprava	dĺžka
<b>58378</b>	strieborná	2,00 M
<b>58379</b>	strieborná	3,00 M
<b>58380</b>	strieborná	4,00 M
<b>58381</b>	strieborná	6,00 M
<b>58379-5</b>	biely	3,00 M
<b>58379-6</b>	biely	4,05 M
<b>58379-7</b>	čierny	3,00 M
<b>58379-8</b>	čierny	4,05 M

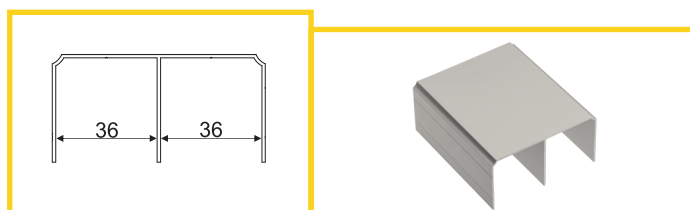

### TLMENIE PRE ŠATNÍKOVE DVERE

obj. číslo	špecifikácia
<b>58565</b>	30 KG / pár
<b>58566</b>	50 KG / pár

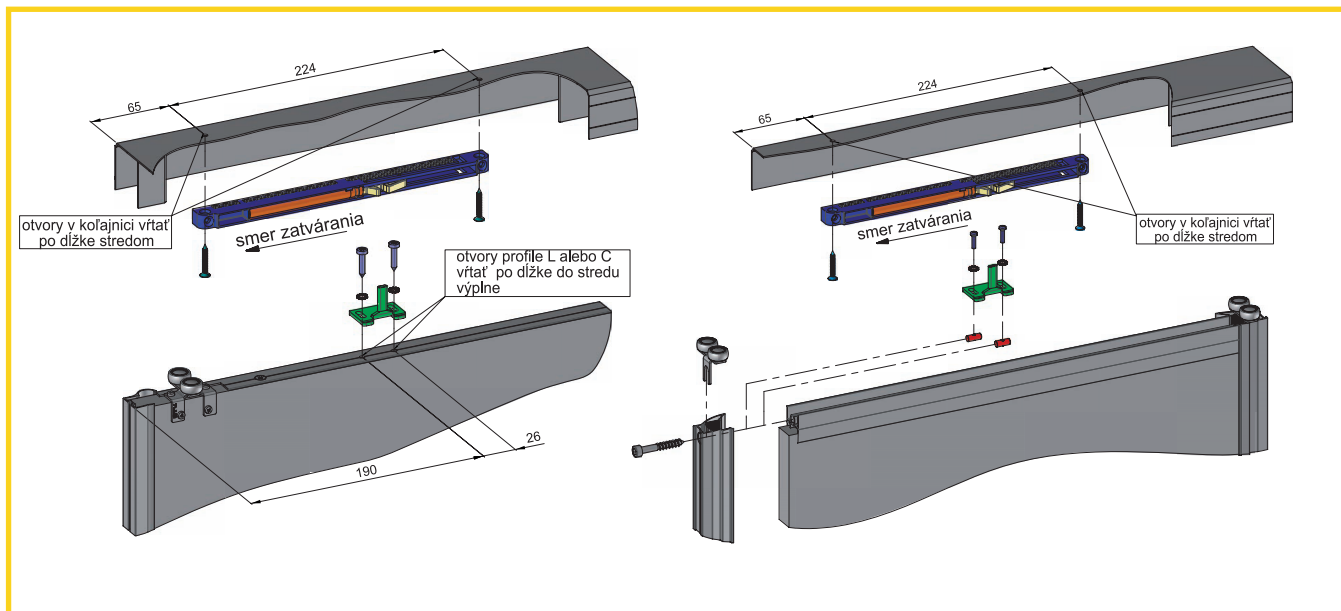
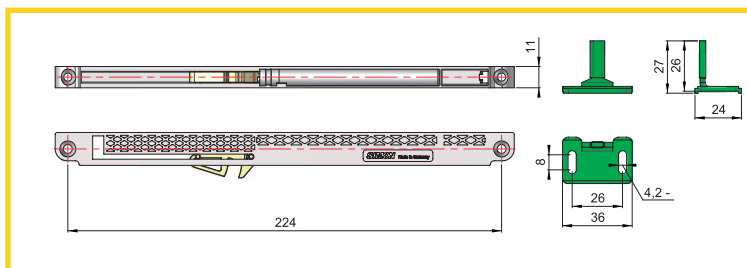

### TLMENIE OBOJSTRANNÉ PRE ŠATNÍKOVE DVERE

obj. číslo	špecifikácia
<b>58568</b>	50 KG / pár
<b>58568-1</b>	Adaptér

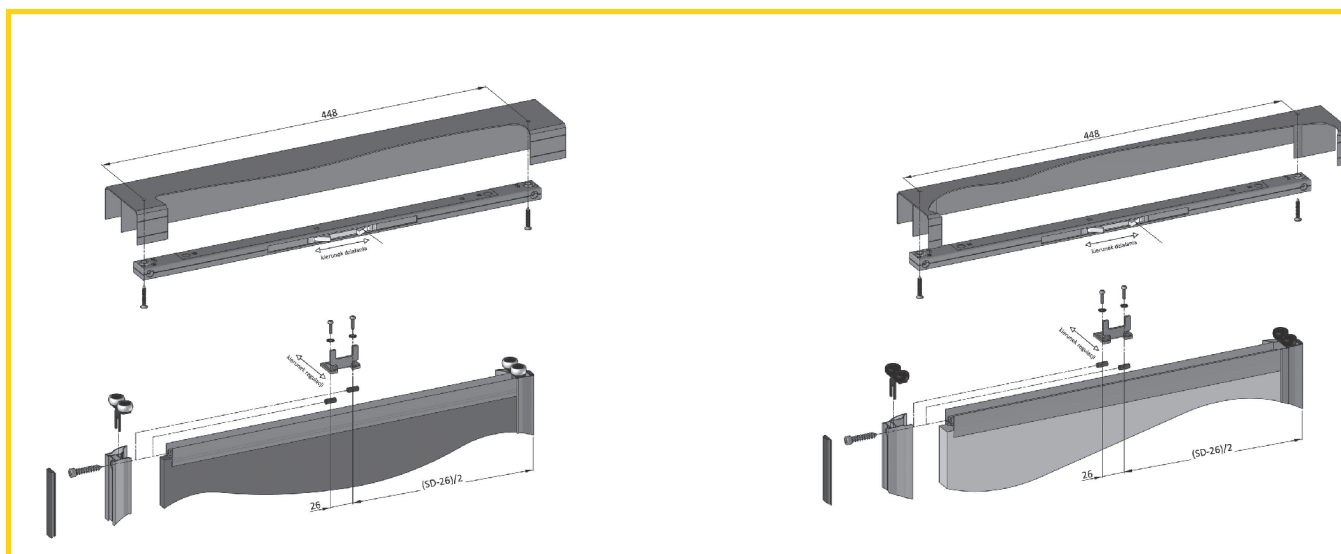
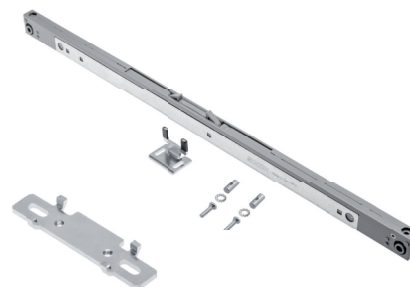
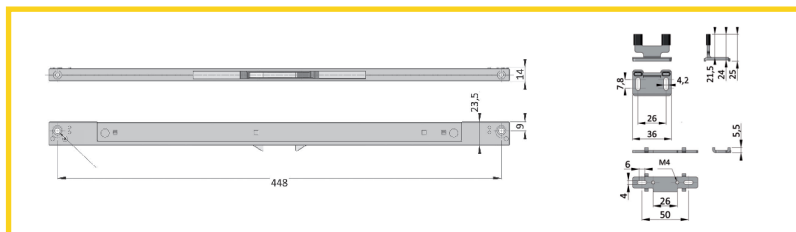

## TLMENIE PRE ŠATNÍKOVÉ DVERE SEVROMATIC

obj. číslo	špecifikácia
<b>58560</b>	SV-25: 14 - 25kg pravé
<b>58561</b>	SV-25: 14 - 25kg ľavé
<b>58562</b>	SV-50: 25 - 50kg pravé
<b>58563</b>	SV-50: 25 - 50kg ľavé



**POZOR !**  
 Mechanizmus tlmíča je navrhnutý pre pravé alebo ľavé dvere. Označenie L - ľavý, P - pravý je na spodnej strane mechanizmu.

**pohľad z vnútra šatníka**

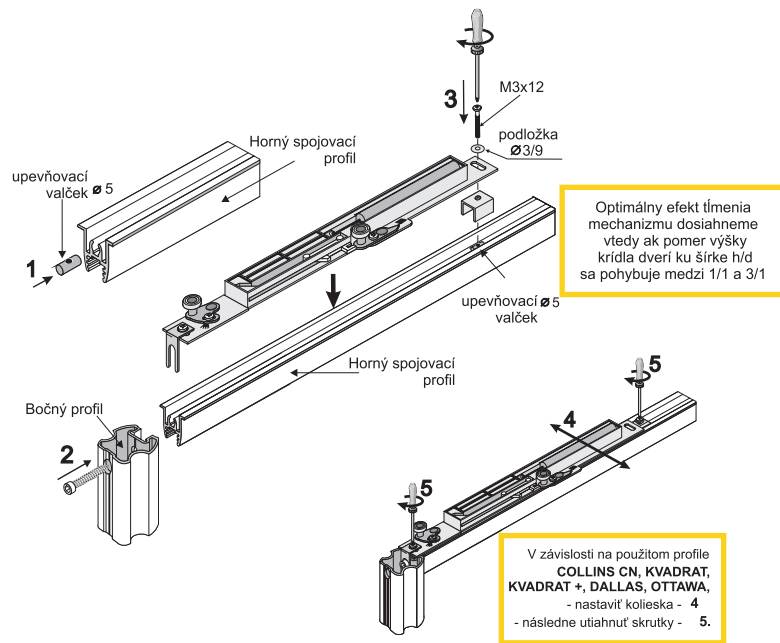
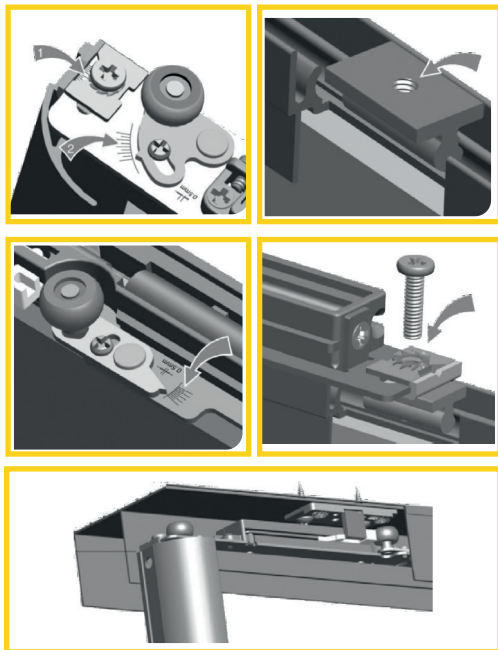
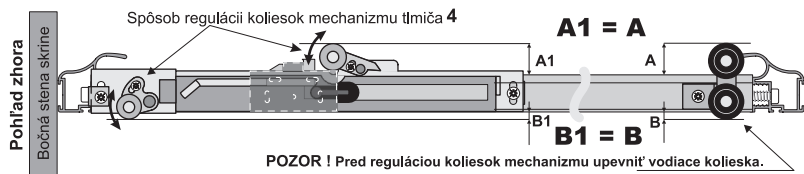

## VEDENIE PRE SKOSENÉ DVERE

obj. číslo	špecifikácia
<b>5860</b>	vodiace koliesko
<b>5860-0</b>	profil 1M
<b>5860-1</b>	profil 1,5M

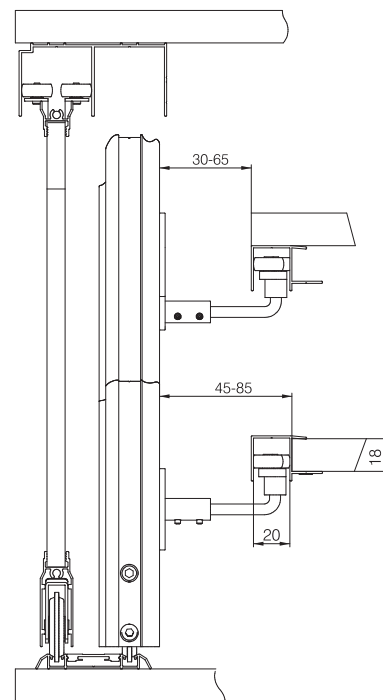
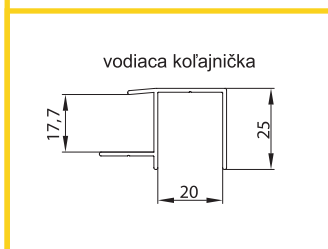
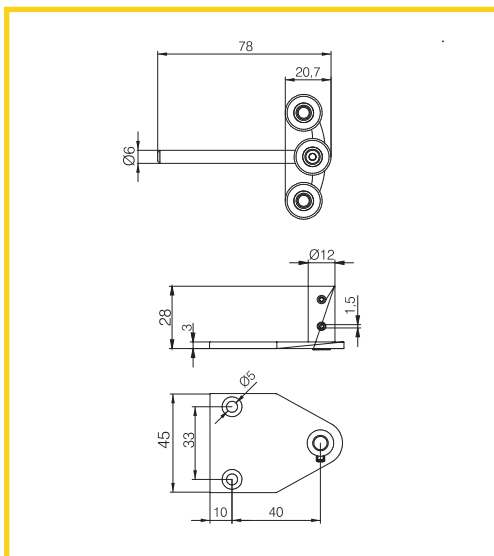

## KOMPONENTY PRE VÝROBU ŠATNÍKOVÝCH DVERÍ

### Vložka pre 4mm sklo

obj. číslo	dĺžka
<b>5854</b>	100M

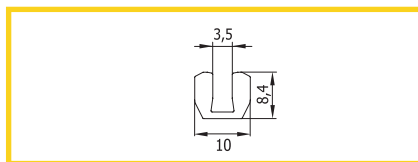

### Vložka pre 6mm sklo

obj. číslo	dĺžka
<b>5854-0</b>	100M

### Pozicioner

obj. číslo
<b>5854-1</b>

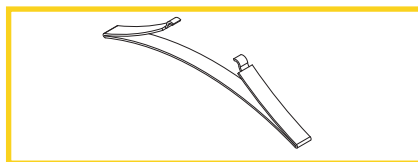

### Vrták

obj. číslo	špecifikácia
<b>5854-8</b>	9,8 / 6mm

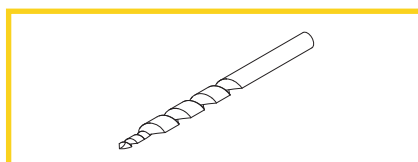

### Bezpečnostná fólia

obj. číslo	šírka	dĺžka
<b>58670-1</b>	400mm	25 bm
<b>58670-2</b>	600mm	25 bm
<b>58671-2</b>	300mm	100 bm
<b>58671-3</b>	400mm	100 bm
<b>58671-4</b>	600mm	100 bm
<b>58671-1</b>	100mm	100 bm

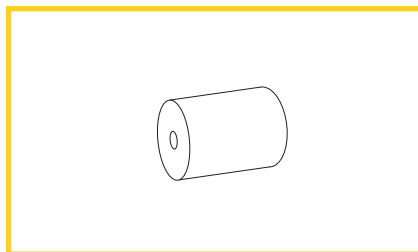

### Šablóna + vrták - pre profil NOVO 18mm

obj. číslo	špecifikácia
<b>58397</b>	šablóna
<b>58398</b>	vrták

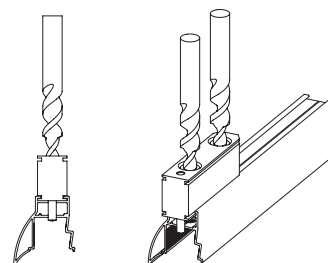
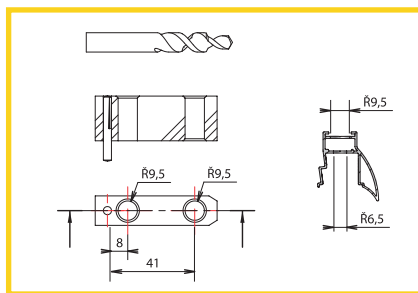

### Stretch fólia

obj. číslo	šírka
<b>9995</b>	500mm
<b>9995-1</b>	250mm
<b>9995-2</b>	100mm



## VARIABILNÉ PREDEĽOVAČE ZÁSUVIEK

### PREDEĽOVACIE PROFILY

obj. číslo	rozmer	dĺžka
<b>35830-1</b>	60 x 2000mm	biela
<b>35830-2</b>	60 x 2000mm	šedá
<b>35830-5</b>	90 x 2000mm	biela
<b>35830-6</b>	90 x 2000mm	šedá

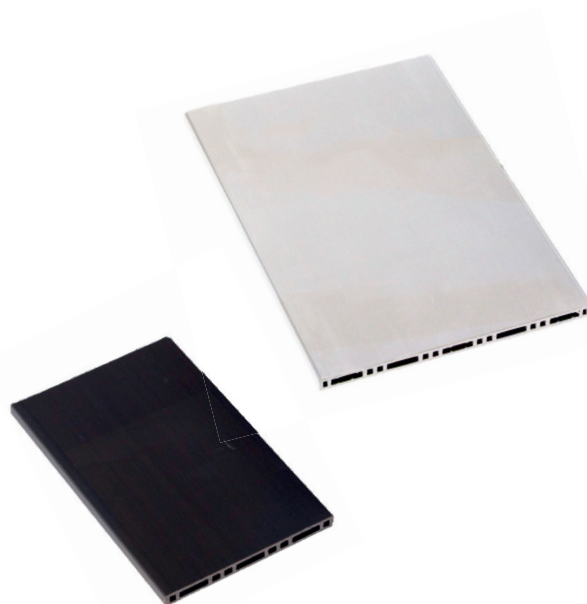
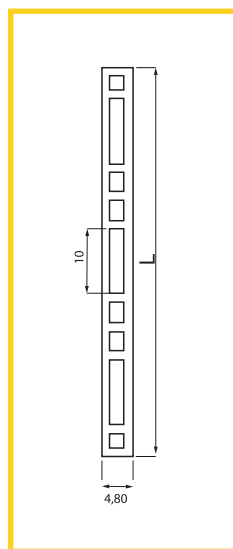

### SPOJKY - VÝŠKA 60MM

obj. číslo	špecifikácia	dĺžka
<b>35831-1</b>	2 - stranný	biela
<b>35831-2</b>	2 - stranný	šedá
<b>35832-1</b>	3 - stranný	biela
<b>35832-2</b>	3 - stranný	šedá
<b>35833-1</b>	4 - stranný	biela
<b>35833-2</b>	4 - stranný	šedá

### SPOJKY - VÝŠKA 90MM

obj. číslo	špecifikácia	dĺžka
<b>35834-1</b>	2 - stranný	biela
<b>35834-2</b>	2 - stranný	šedá
<b>35835-1</b>	3 - stranný	biela
<b>35835-2</b>	3 - stranný	šedá
<b>35836-1</b>	4 - stranný	biela
<b>35836-2</b>	4 - stranný	šedá





### VÝSUVNÝ KÔŠ

obj. číslo	S	A
<b>58650-10</b>	260-285	255
<b>58650-20</b>	360-385	355
<b>58650-30</b>	460-485	455
<b>58650-40</b>	560-585	555

\* povrchová úprava koša - BIELA

\* ku košu je potrebné objednať guľičkový plnovýsuv bez tĺmenia alebo s tĺmením.

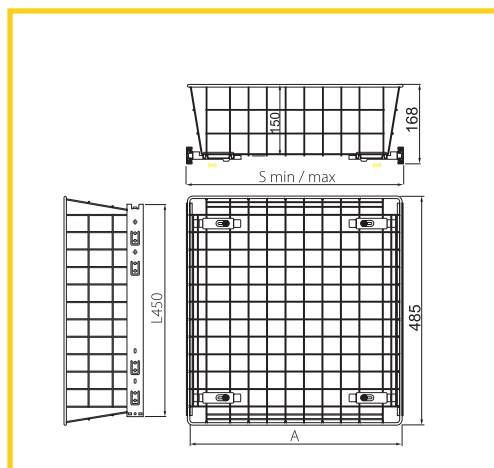
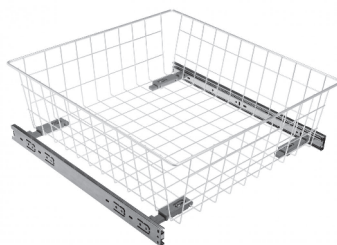

### VÝSUVNÝ VEŠIAK

obj. číslo	dĺžka	L
<b>3549</b>	250mm	222mm
<b>3550</b>	300mm	277mm
<b>3551</b>	350mm	324mm
<b>3552</b>	400mm	372mm
<b>3553</b>	450mm	423mm
<b>3554</b>	500mm	470mm

Povrchová úprava: nikel

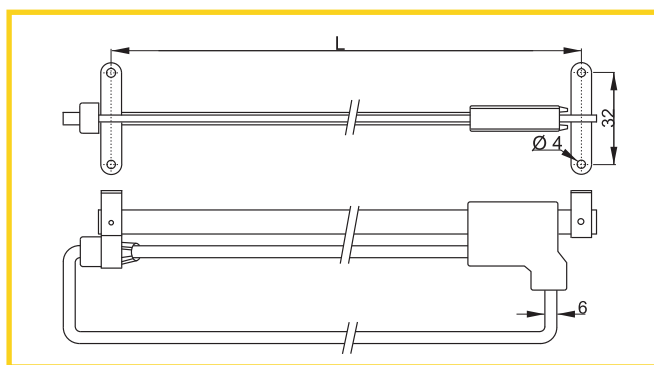

### VÝSUVNÝ VEŠIAK WSD

obj. číslo	L	C
<b>35540-1</b>	302	270
<b>35540-2</b>	352	320
<b>35540-3</b>	402	370
<b>35540-4</b>	452	420

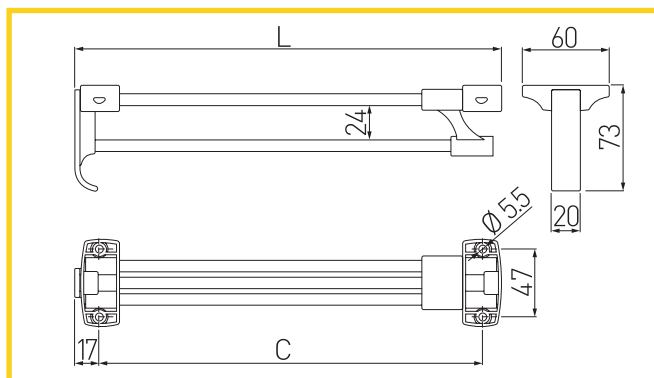

### VÝSUVNÝ VEŠIAK NA NOHAVICE SMART

obj. číslo	šírka skrinky	(A) min. - max.
<b>58600-1</b>	600 MM	560 - 568 MM
<b>58600-2</b>	700 MM	660 - 668 MM
<b>58600-3</b>	800 MM	760 - 768 MM
<b>58600-4</b>	900 MM	860 - 868 MM

Použitý guľičkový výsuv s tĺmením

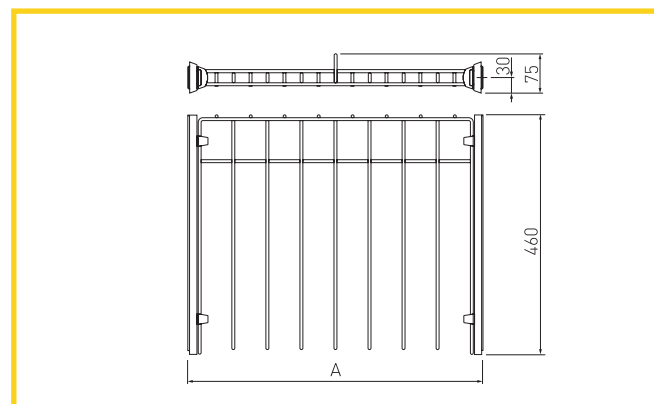

### SKLOPNÝ VEŠIAK

obj. číslo	špecifikácia
<b>58630-1</b>	600-830
<b>58630-2</b>	830-1150
<b>58630-3</b>	450-600

Max. zaťaženie - 8 kg  
Úprava: čierna + nikel

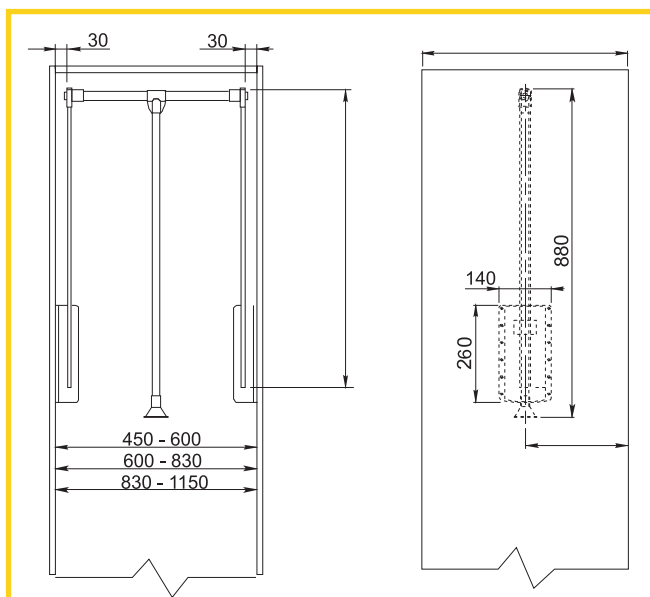

### SKLOPNÝ VEŠIAK BIELY

obj. číslo	špecifikácia
<b>58630-5</b>	600-830
<b>58630-6</b>	830-1150

Max. zaťaženie - 8 kg  
Úprava: biela + nikel



### VÝSUVNÝ VEŠIAK NA NOHAVICE

obj. číslo	špecifikácia
<b>5861-7</b>	pravé uchytenie
<b>5861-8</b>	ľavé uchytenie

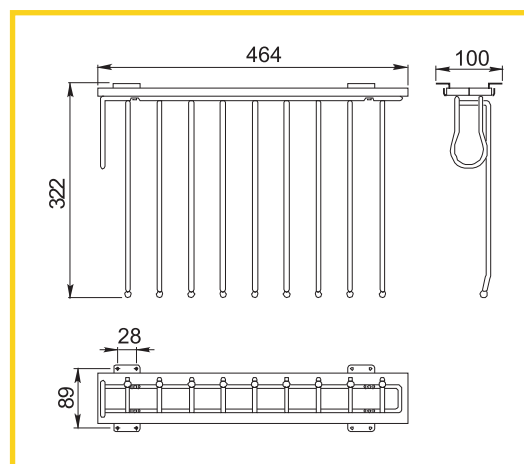

### VÝSUVNÝ VEŠIAK NA NOHAVICE

obj. číslo	úprava
<b>5862-1</b>	strieborná

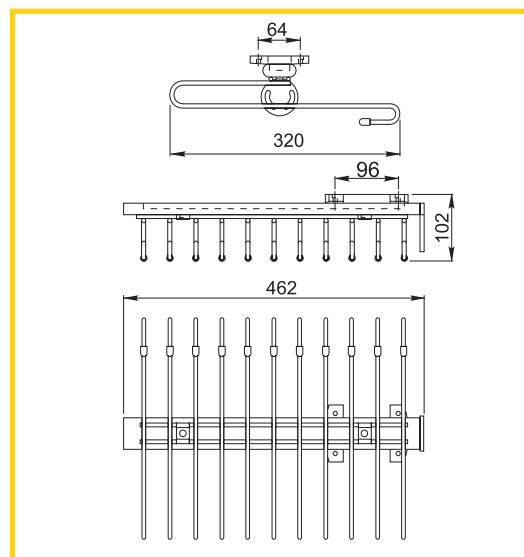

## VÝSUVNÝ VEŠIAK NA NOHAVICE ELITE

### BIELY

obj. číslo	šírka skrinky	min. - max.
<b>58640-1</b>	600 MM	560 - 618 MM
<b>58640-2</b>	700 MM	660 - 718 MM
<b>58640-3</b>	800 MM	760 - 818 MM
<b>58640-4</b>	900 MM	860 - 918 MM



### ANTRACIT

obj. číslo	šírka skrinky	min. - max.
<b>58641-1</b>	600 MM	560 - 618 MM
<b>58641-2</b>	700 MM	660 - 718 MM
<b>58641-3</b>	800 MM	760 - 818 MM
<b>58641-4</b>	900 MM	860 - 918 MM

## VÝSUVNÝ KOŠÍK ELITE

### BIELY

obj. číslo	šírka skrinky	min. - max.
<b>58642-1</b>	600 MM	560 - 618 MM
<b>58642-2</b>	700 MM	660 - 718 MM
<b>58642-3</b>	800 MM	760 - 818 MM
<b>58642-4</b>	900 MM	860 - 918 MM



### ANTRACIT

obj. číslo	šírka skrinky	(A) min. - max.
<b>58643-1</b>	600 MM	560 - 618 MM
<b>58643-2</b>	700 MM	660 - 718 MM
<b>58643-3</b>	800 MM	760 - 818 MM
<b>58643-4</b>	900 MM	860 - 918 MM

## VÝSUVNÝ KOŠÍK NA OBUV ELITE

### BIELY

obj. číslo	šírka skrinky	min. - max.
<b>58644-1</b>	600 MM	560 - 618 MM
<b>58644-2</b>	700 MM	660 - 718 MM
<b>58644-3</b>	800 MM	760 - 818 MM
<b>58644-4</b>	900 MM	860 - 918 MM



### ANTRACIT

obj. číslo	šírka skrinky	min. - max.
<b>58645-1</b>	600 MM	560 - 618 MM
<b>58645-2</b>	700 MM	660 - 718 MM
<b>58645-3</b>	800 MM	760 - 818 MM
<b>58645-4</b>	900 MM	860 - 918 MM

## VÝSUVNÝ ORGANIZÉR ELITE

### BIELY

obj. číslo	šírka skrinky	min. - max.
<b>58646-1</b>	600 MM	560 - 618 MM
<b>58646-2</b>	700 MM	660 - 718 MM
<b>58646-3</b>	800 MM	760 - 818 MM
<b>58646-4</b>	900 MM	860 - 918 MM



### ANTRACIT

obj. číslo	šírka skrinky	min. - max.
<b>58647-1</b>	600 MM	560 - 618 MM
<b>58647-2</b>	700 MM	660 - 718 MM
<b>58647-3</b>	800 MM	760 - 818 MM
<b>58647-4</b>	900 MM	860 - 918 MM