

KOLIESKO PRIAME POGUMOVANÉ

obj. číslo	∅	V	A	B	C	M
2132-0	25mm	28	19	42	32	13
2132	32mm	39	20	58	46	16
2132-1	40mm	43	20	58	46	16

Statické zaťaženie : 25 kg / 1 koliesko

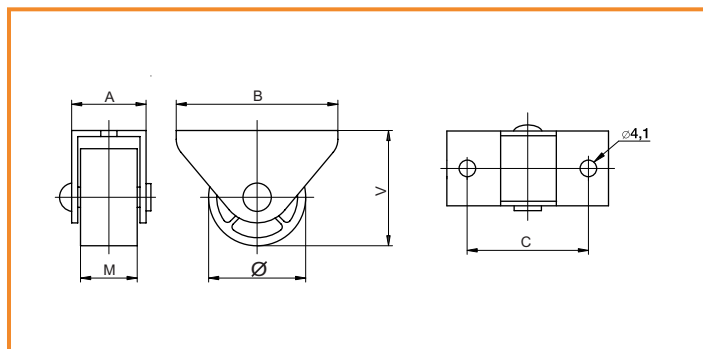

KOLIESKO PRIAME 25MM

obj. číslo	nosnosť
2134	18kg

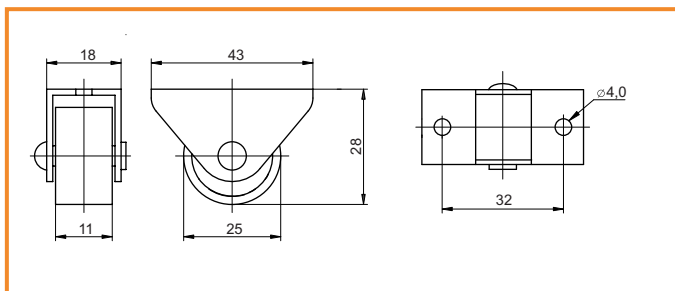

KOLIESKO PRIAME 32MM

obj. číslo	nosnosť
2133	35kg

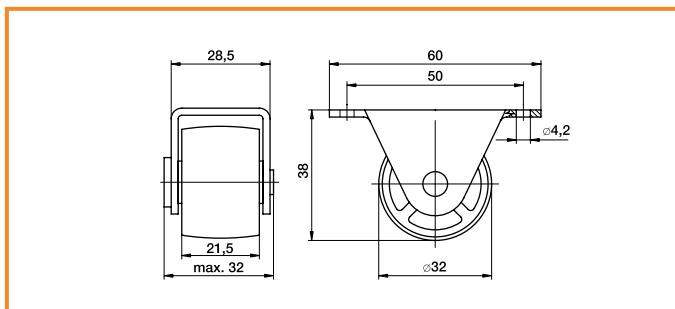

KOLIESKO PRIAME INLAY

obj. číslo	nosnosť
2688-1	30kg

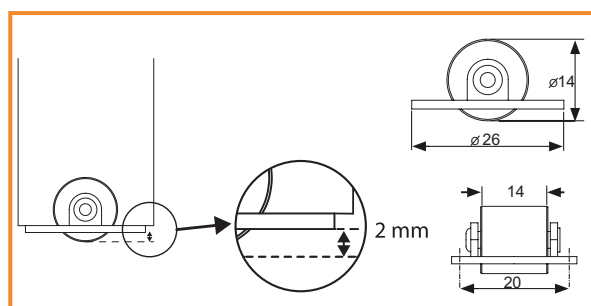

KOLIESKO PRIAME 50MM

obj. číslo	nosnosť
2136	50kg

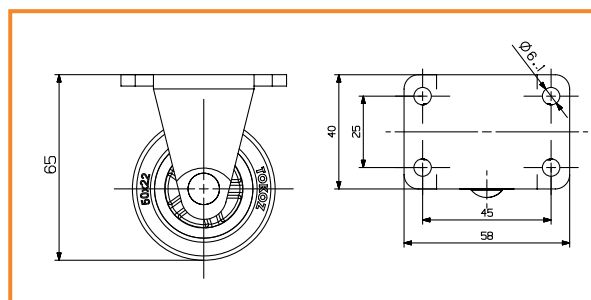

KOLIESKO PRIAME 50MM

obj. číslo	nosnosť
2136-2	50kg

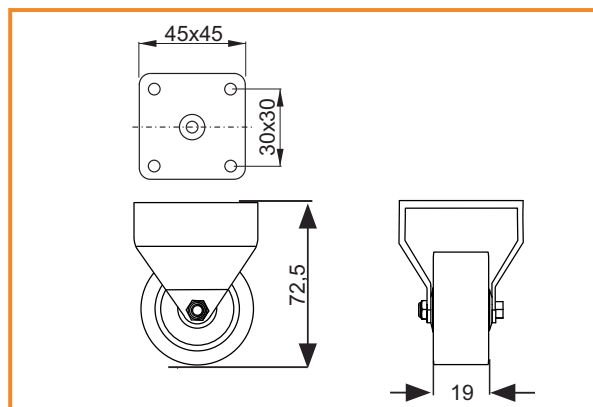

KOLIESKO OTOČNÉ 24MM

obj. číslo	nosnosť
2135	10kg

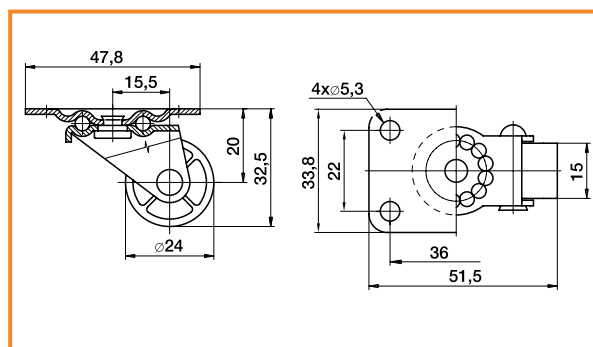

KOLIESKO OTOČNÉ 32MM

obj. číslo	nosnosť
2138	20kg

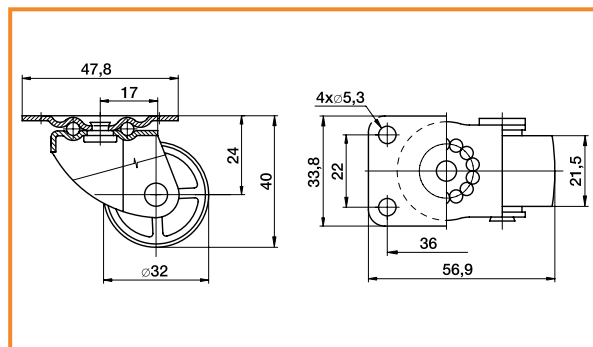

KOLIESKO OTOČNÉ

obj. číslo	nosnosť	A (mm)
2137	25kg	50mm
2136-1	25kg / s brzdou	50mm
2140	40kg	75mm
2140-1	40kg/ s brzdou	75mm

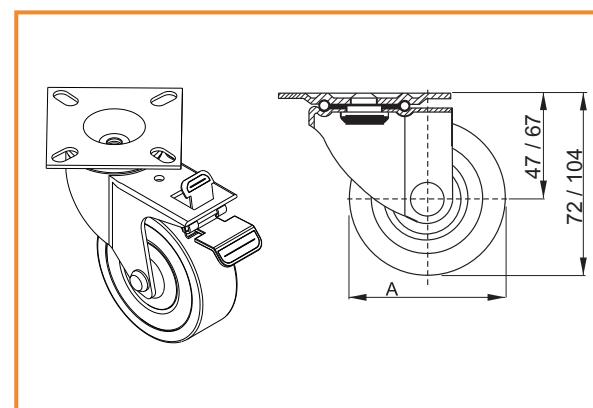

KOLIESKO OTOČNÉ 35MM

obj. číslo	nosnosť
2141-1	25kg
2141-2	25kg / s brzdou

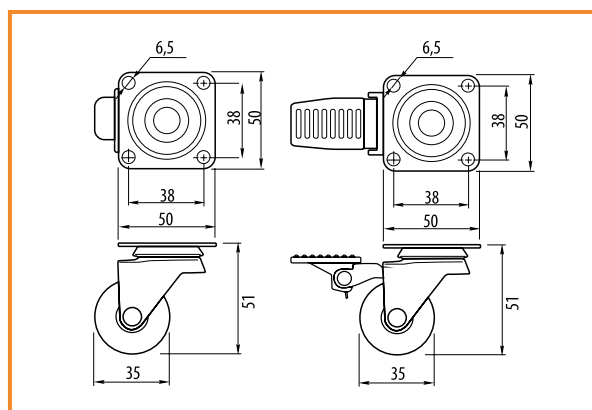

KOLIESKO OTOČNÉ TRANSPARENT „SHIFT“

obj. číslo	nosnosť	A (mm)
2142-1	25kg	50mm
2142-2	25kg / s brzdou	50mm
2142-5	40kg	75mm
2142-6	40kg / s brzdou	75mm

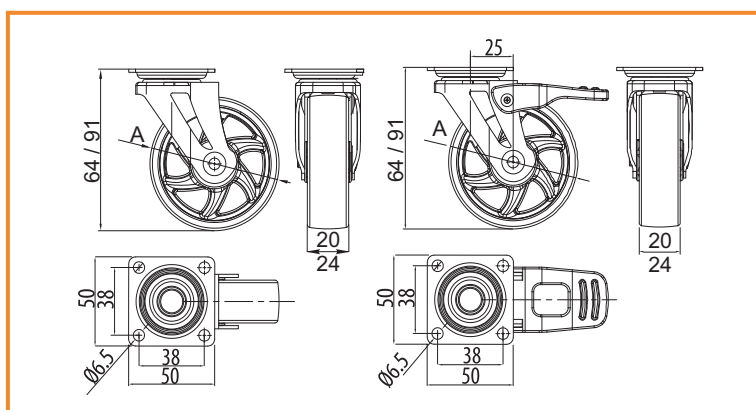

KOLIESKO OTOČNÉ TUZER

obj. číslo	nosnosť	 A (mm)
2145-1	40kg	50mm
2145-2	40kg s brzdou	50mm
2145-3	50kg	75mm
2145-4	50kg s brzdou	75mm

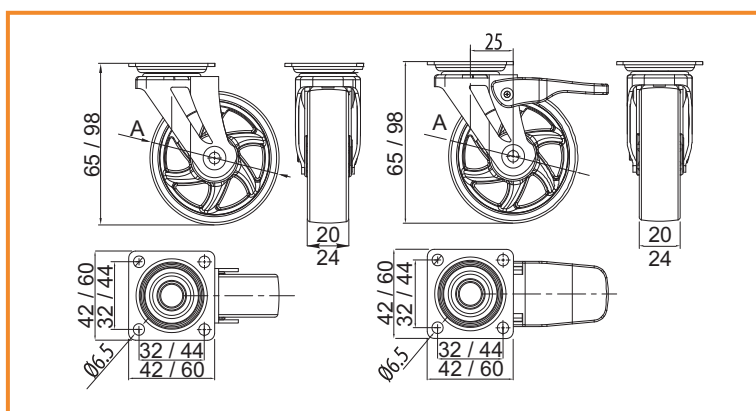

KOLIESKO S PLATNIČKOU

obj. číslo	nosnosť	C (mm)
2685	15 kg	30mm
2679-1	18kg	40mm
2679-2	18kg/ s brzdou	40mm
2682	22 kg	50mm
2688	22 kg/ s brzdou	50mm

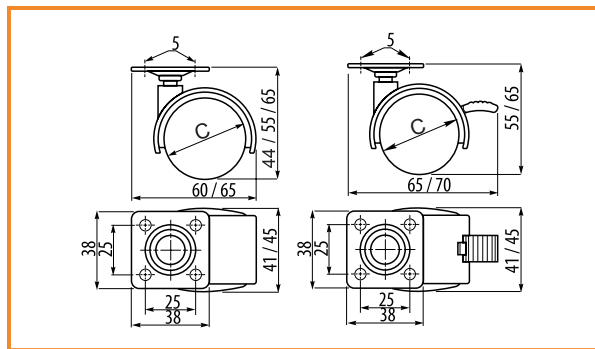

KOLIESKO POGUMOVANÉ 50MM S PLATNIČKOU

obj. číslo	špecifikácia
2682-1	bez brzdy
2682-2	s brzdou

max. zaťaženie: 22 kg

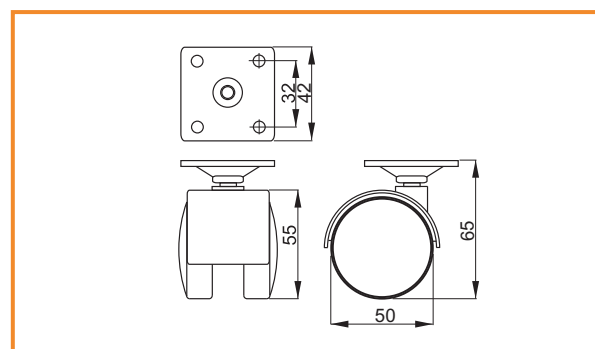

KLZÁK S PLATNIČKOU 7507, 7505

obj. číslo	model	B	V
2836	7507	65mm	46mm
2837	7505	55mm	45mm

Max. zaťaženie : 35 kg

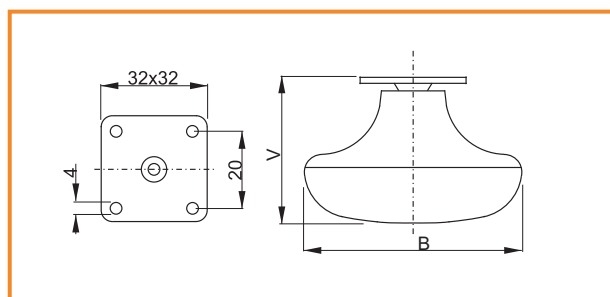

KLZÁK S PLATNIČKOU GL-65

obj. číslo	nosnosť
2855	25kg

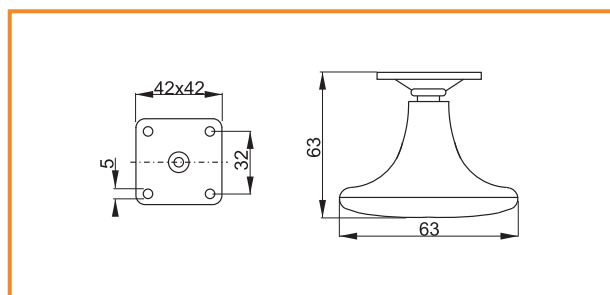

REKTIFIKAČNÝ PÄTKA IKO

obj. číslo	špecifikácia	rozmer
26922-1	pätka IKO 1	M6x27
26922-2	pätka IKO 2	M6x27
26922-5	závrtná matica	M6x8,5x14

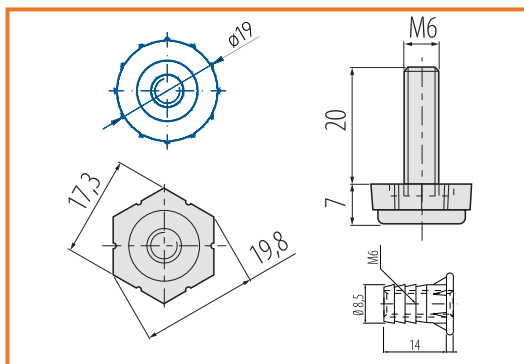

REKTIFIKAČNÁ PÄTKA - BETA

obj. číslo	špecifikácia	rozmer
2692	pätka BETA	M6x24mm
2692-1	závrtná matica	M6x9x15mm

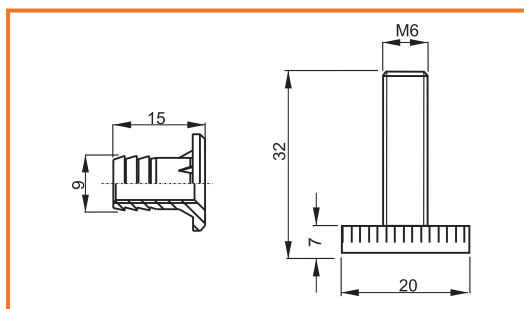

REKTIFIKAČNÁ PÄTKA - ALPHA

obj. číslo	špecifikácia	rozmer
2692-2	pätka ALPHA	M8x25mm
2692-3	závrtná matica	M8x12x15mm

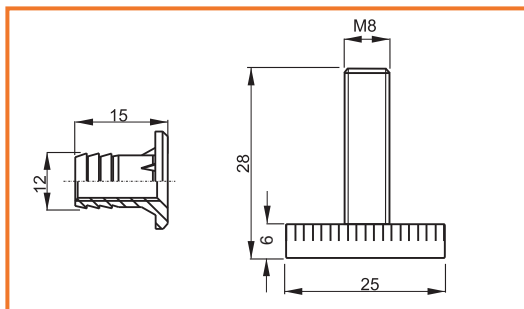

REKTIFIKAČNÁ PÄTKA - TIME

obj. číslo	špecifikácia	rozmer
2692-4	pätka TIME	M10x50mm
2692-5	závrtná matica	M10x12x19mm

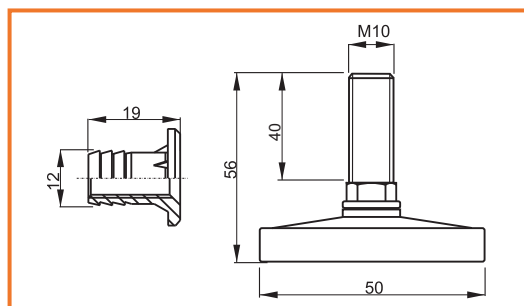

REKTIFIKAČNÁ PÄTKA - CUP

obj. číslo	úprava	rozmer $\varnothing \times S$
2691-0	čierna	50x17mm
2691-00	strieborna	50x17mm
2691-1	čierna	50x27mm
2691-2	čierna	50x44mm

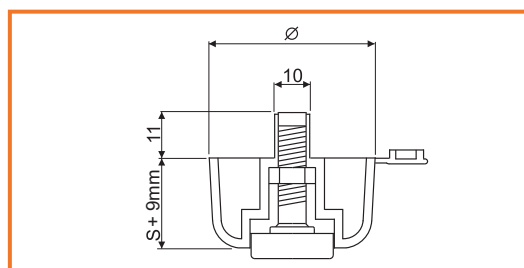

REKTIFIKAČNÁ PÄTKA - KNUR

obj. číslo	úprava	rozmer
2691-3	čierna	panel 18mm

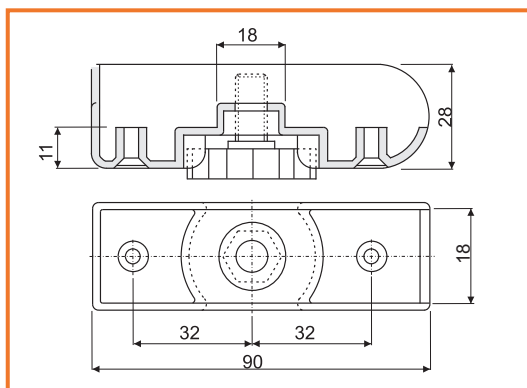

PLASTOVÝ KLINEC

obj. číslo	farba
2693	hnedý
2693-2	biely

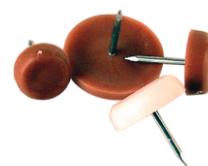
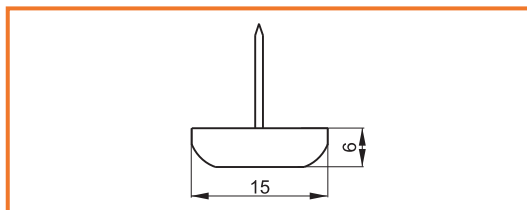

PLASTOVÝ KLINEC S FILCOM

obj. číslo	špecifikácia
2693-8	hnedý

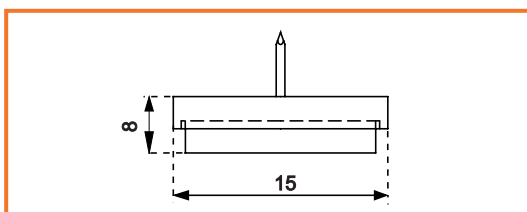

KLZÁK NASTREĽOVACÍ

obj. číslo	farba
99-1037	hnedý
99-1038	biely

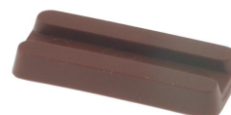
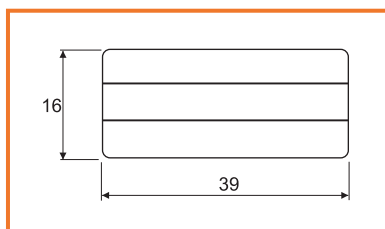

KLZÁK ŠRUBOVACÍ

obj. číslo	farba
99-1040	hnedá
99-1041	biela

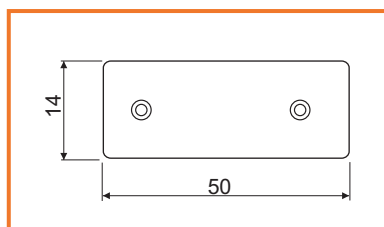

KLAPAČKA

obj. číslo	farba
3988-4	hnedá
3988-5	biela

